

# CATALOG



>Optical rotary encoders





# DATALOGIC: SOLUTIONS FOR INDUSTRIAL AUTOMATION

Datalogic Industrial Automation is an industry-leader in products and solutions for material handling, traceability, inspection and detection applications.

With the acquisitions of Accu-Sort and PPT Vision in 2012, the company offers a comprehensive portfolio of products, technologies and solutions delivered by a team of skilled professionals dedicated in providing superior service to customers.

Datalogic is the partner of choice for organizations in the Industrial Automation market.

## Factory Automation

- AUTOMOTIVE
- ELECTRONICS
- FOOD & BEVERAGE
- GENERAL MANUFACTURING
- HEALTHCARE - PHARMACEUTICAL

## Transportation & Logistics

- AIRPORTS
- COURIER, EXPRESS PARCEL (CEP)
- POSTAL
- RETAIL DISTRIBUTION

## Product portfolio

Datalogic Industrial Automation has the most comprehensive offering of products and solutions for traceability, inspection and detection applications in factory automation and logistics processes: industrial LASER scanners, cameras and vision systems, sensors, machine safety devices and LASER markers.

## Identification

Even the most demanding and efficient automation of identification processes can leverage Datalogic Industrial Automation's leadership in the market. We manufacture the world's most comprehensive family of fixed-mount line and omnidirectional scanners.

We also offer the latest CCD vision technology with the world's largest installed base of CCD systems for bar code reading and dimensioning.

All of our AUTO-ID products and solutions leverage the broadest decoding library that has been developed through the years. Datalogic's comprehensive AUTO-ID portfolio is used in a wide range of applications and machines which are behind many of the everyday processes that keeps the global economy running.

## Sensors & Safety

Datalogic Industrial Automation offers a best-in-class, comprehensive product portfolio of photoelectric and proximity sensors, rotary encoders, temperature controllers and measurement devices, as well as type 2 and type 4 safety light curtains.

These product lines provide solutions for applications involving color, contrast and luminescence, label detection, dimensional and distance measurement, in addition to machine safeguarding and access control in dangerous areas.

## Machine Vision

The Datalogic Industrial Automation machine vision product line encompasses both hardware and software while covering a wide range of performance and price point requirements. The vision portfolio of products and solutions ranges from standalone compact smart cameras to the highest performance embedded processors.

## Laser Marking

Laser Marking sources and systems provide value driven marking solutions for automotive, metal tools, medical, electronics and packaging. Datalogic Industrial Automation offers an extensive range of state-of-the-art technology, excellent performance and high reliability marking equipment.





INTRODUCTION	6
<hr/>	
SELECTION AND LINE OVERVIEW	8
<hr/>	
INCREMENTAL ENCODERS	12
<hr/>	
ENC41 Basic Line	14
ENC58 Extended Line	18
IEP58 Programmable Line	24
OEK-4 Kit for Conveyor Belt	28
<hr/>	
ABSOLUTE ENCODERS	30
<hr/>	
AST58 SSI Single-Turn	32
AMT58 SSI Multi-Turn	36
AMT58 Modular Fieldbus Multi-Turn	40
AMT58 Integrated Fieldbus Multi-Turn	44
<hr/>	
LINEAR MEASUREMENT ACCESSORIES	48
<hr/>	
DW Draw Wire	50
MW Metric Wheel	52



# INTRODUCTION

## OPTICAL ROTARY ENCODERS

### What is an encoder

Optical rotary encoders (or shaft encoders) are made to provide output signals or digital data based on physical mechanical measures:

- Rotational speed of the encoder shaft
- Direction of rotation
- Angular position of the shaft
- Linear displacement (with draw wires or measuring wheels)

Encoders are used as sensors for motion control, length measurement and positioning applications



### How is made

The encoder shaft transmits the rotation to a coded disk made of lines which shutter the light from photo-emitters to photo-receivers, thus generating a variable electrical signal. According to the different coded disk mask and electrical circuit there are two types of encoders: incremental or absolute.

### Incremental encoders

Incremental encoders produce sinusoidal or square wave outputs, which give an incremental number of pulses per revolution of the shaft.

The resolution is defined as Pulse Per Revolution (PPR).

The signals start at the power up and the shaft position is not retained when encoder is switched-off, so they can be used to control rotation speed and direction, but can't provide absolute position. A-B-0 (90° phase shifted tracks and zero) and /A-/B-/0 complement outputs are used to detect rotation direction, increase resolution and avoid disturbances. The 0 index is used as reference marker for the 'home' position. Datalogic incremental encoders offer a Smart Push-Pull & Line Driver output which is suitable for both configurations.

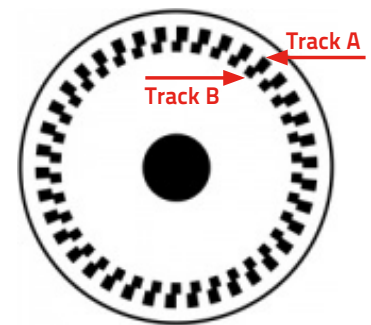
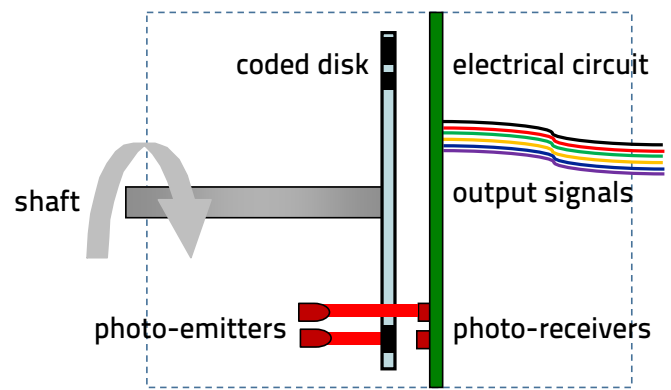

### Absolute encoders

Absolute encoders generate a multi-bit digital data information, providing the actual angular position of the shaft. Single-turn absolute encoders repeat the code for every shaft revolution. Multi-turn absolute encoders increase the code at each shaft revolution. Shaft position is retained when the absolute encoder is switched-off, so it can provide the absolute position, as well as rotation speed or direction. Absolute encoders have a different bit mask for each angular position, resolution is defined as Code Per Revolution (CPR) and also expressed in bits. The simple example shows a 4 bit mask, that's 16 CPR. Datalogic absolute encoders are available either with SSI® serial synchronous interface, or Fieldbus interfaces as CANopen®, Devicenet, EtherCAT, Profibus, or Profinet.

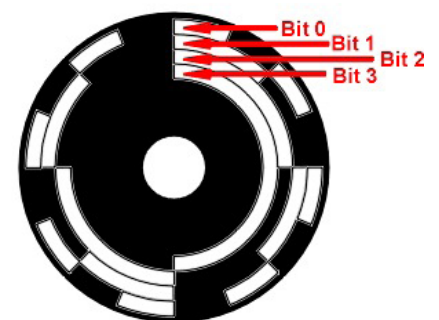

# APPLICATIONS

**Motion control** is the most common application, the encoder is mounted directly to the end of a motor via a shaft and provides feedback to a drive to verify that the speed and direction is correct

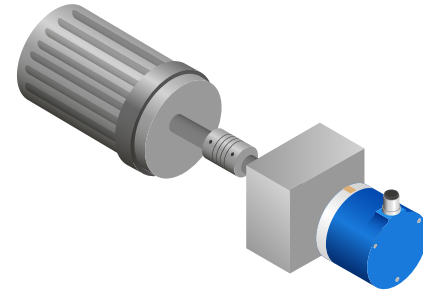

**Web speed or tension control** is another application in which an encoder is mounted to, so that any unevenness in the rotating speed of the tension roller is fed to a controller to maintain an even tension

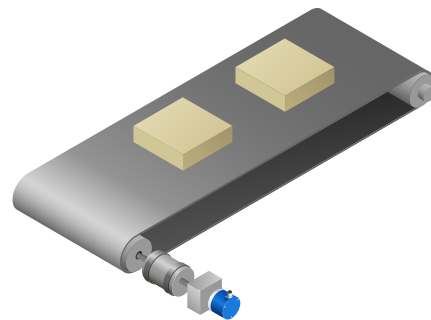

**Length measurement applications** use an encoder mounted on a wheel, in order to convert a linear movement into a rotation angle, or number of rotations, so providing a length measurement to control cutting, folding or other operations

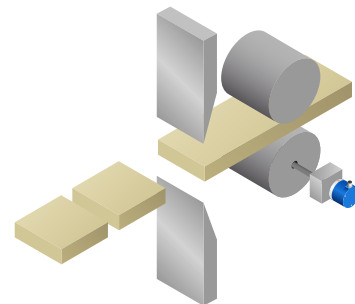

**Conveying** is another common industry application where encoders are used to control speed and position of a motor or intermediate axle shafts along conveyors. Encoder information is synchronized, for example, to control barcode scanners or label printers

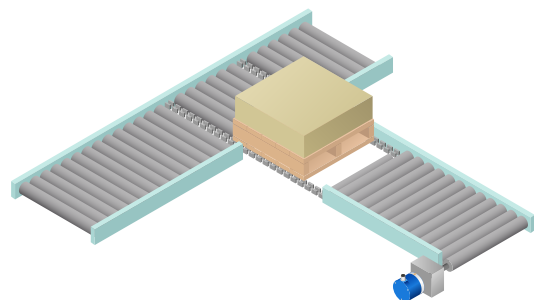

**Automated packaging machinery** has many axes of high-speed rotary motion that require feedback for motion control, hence, the frequent need of encoders for speed or position feedback, length measurement and positioning applications

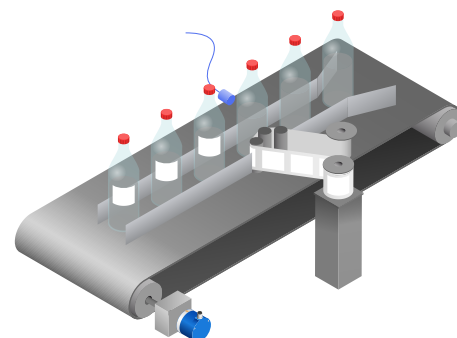

# INCREMENTAL ENCODERS

## SELECTION AND LINE OVERVIEW

LINE AND CASE DIAMETER	SHAFT TYPE AND DIAMETER	RESOLUTION	CONNECTION
ENC41 = incremental Ø41	H06 = hollow Ø6mm	0100 = 100 PPR	C15 = cable 1.5m
ENC58 = incremental Ø58	H14 = hollow Ø14mm	0360 = 360 PPR	M12 = M12 connector
	H15 = hollow Ø15mm	0500 = 500 PPR	M23 = M23 connector
	S06 = solid Ø6mm	1000 = 1000 PPR	
		1024 = 1024 PPR	
		2000 = 2000 PPR	
		2048 = 2048 PPR	
		2500 = 2500 PPR	
		4096 = 4096 PPR	
		5000 = 5000 PPR	
		10000 = 10000 PPR	
		PROG = programmable	

### COMPACT BASIC LINE

#### ENC41

# ENC41



Power supply	5-30 Vdc	
Resolution	up to 4096 pulse per revolution (PPR)	
Output signals	A/B and /A/B/O	
Output circuit	Smart Push-Pull & Line Driver	
Connection	cable 1.5m	
Case diameter	Ø 40.5 mm	
Case material	fibre glass epoxy resin	
Flange material	anticorrosive aluminium, UNI EN AW-6082	
Shaft material	stainless steel, non-magnetic, UNI EN 4305	
Shaft type	hollow shaft	solid shaft
Shaft diameter	o Ø 6 mm	• Ø 6 mm
100 PPR / cable	ENC41-H06-0100-C15	ENC41-S06-0100-C15
360 PPR / cable	ENC41-H06-0360-C15	ENC41-S06-0360-C15
500 PPR / cable	ENC41-H06-0500-C15	ENC41-S06-0500-C15
1000 PPR / cable	ENC41-H06-1000-C15	ENC41-S06-1000-C15
1024 PPR / cable	ENC41-H06-1024-C15	ENC41-S06-1024-C15
2048 PPR / cable	ENC41-H06-2048-C15	ENC41-S06-2048-C15
4096 PPR / cable	ENC41-H06-4096-C15	ENC41-S06-4096-C15



EXTENDED LINE

ENC58

# ENC58



Power supply	5-30 Vdc			
Resolution	up to 10000 pulse per revolution (PPR) and programmable mod.			
Output signals	A/B/O and /A/B/O			
Output circuit	Smart Push-Pull & Line Driver			
Connection	cable 1.5m or connector M12 or M23			
Case diameter	Ø 58 mm			
Case material	anticorodal aluminium, UNI EN AW-6082			
Flange material	anticorodal aluminium, UNI EN AW-6082			
Shaft material	stainless steel, non-magnetic - UNI EN 4305			
Shaft type	hollow shaft		solid shaft	
Shaft diameter	o Ø 14 mm	o Ø 15 mm	● Ø 6 mm	● Ø 10 mm
500 PPR/cable	ENC58-H14-0500-C15	ENC58-H15-0500-C15	ENC58-S06-0500-C15	ENC58-S10-0500-C15
1000 PPR/cable	ENC58-H14-1000-C15	ENC58-H15-1000-C15	ENC58-S06-1000-C15	ENC58-S10-1000-C15
1024 PPR/cable	ENC58-H14-1024-C15	ENC58-H15-1024-C15	ENC58-S06-1024-C15	ENC58-S10-1024-C15
2000 PPR/cable	ENC58-H14-2000-C15	ENC58-H15-2000-C15	ENC58-S06-2000-C15	ENC58-S10-2000-C15
2048 PPR/cable	ENC58-H14-2048-C15	ENC58-H15-2048-C15	ENC58-S06-2048-C15	ENC58-S10-2048-C15
2500 PPR/cable	ENC58-H14-2500-C15	ENC58-H15-2500-C15	ENC58-S06-2500-C15	ENC58-S10-2500-C15
5000 PPR/cable	ENC58-H14-5000-C15	ENC58-H15-5000-C15	ENC58-S06-5000-C15	ENC58-S10-5000-C15
10000 PPR/cable	ENC58-H14-10000-C15	ENC58-H15-10000-C15	ENC58-S06-10000-C15	ENC58-S10-10000-C15
500 PPR/M12	ENC58-H14-0500-M12	ENC58-H15-0500-M12	-	ENC58-S10-0500-M12
1000 PPR/M12	ENC58-H14-1000-M12	ENC58-H15-1000-M12	-	ENC58-S10-1000-M12
1024 PPR/M12	ENC58-H14-1024-M12	ENC58-H15-1024-M12	-	ENC58-S10-1024-M12
2000 PPR/M12	ENC58-H14-2000-M12	ENC58-H15-2000-M12	-	ENC58-S10-2000-M12
2048 PPR/M12	ENC58-H14-2048-M12	ENC58-H15-2048-M12	-	ENC58-S10-2048-M12
2500 PPR/M12	ENC58-H14-2500-M12	ENC58-H15-2500-M12	-	ENC58-S10-2500-M12
5000 PPR/M12	ENC58-H14-5000-M12	ENC58-H15-5000-M12	-	ENC58-S10-5000-M12
10000 PPR/M12	ENC58-H14-10000-M12	ENC58-H15-10000-M12	-	ENC58-S10-10000-M12
500 PPR/M23	ENC58-H14-0500-M23	ENC58-H15-0500-M23	ENC58-S06-0500-M23	ENC58-S10-0500-M23
1000 PPR/M23	ENC58-H14-1000-M23	ENC58-H15-1000-M23	ENC58-S06-1000-M23	ENC58-S10-1000-M23
1024 PPR/M23	ENC58-H14-1024-M23	ENC58-H15-1024-M23	ENC58-S06-1024-M23	ENC58-S10-1024-M23
2000 PPR/M23	ENC58-H14-2000-M23	ENC58-H15-2000-M23	ENC58-S06-2000-M23	ENC58-S10-2000-M23
2048 PPR/M23	ENC58-H14-2048-M23	ENC58-H15-2048-M23	ENC58-S06-2048-M23	ENC58-S10-2048-M23
2500 PPR/M23	ENC58-H14-2500-M23	ENC58-H15-2500-M23	ENC58-S06-2500-M23	ENC58-S10-2500-M23
5000 PPR/M23	ENC58-H14-5000-M23	ENC58-H15-5000-M23	ENC58-S06-5000-M23	ENC58-S10-5000-M23
10000 PPR/M23	ENC58-H14-10000-M23	ENC58-H15-10000-M23	ENC58-S06-10000-M23	ENC58-S10-10000-M23
PROG PPR/M23	ENC58-H14-PROG-M23	ENC58-H15-PROG-M23	-	ENC58-S10-PROG-M23

# ABSOLUTE ENCODERS

## SELECTION AND LINE OVERVIEW

LINE AND CASE DIAMETER	SHAFT TYPE AND DIAMETER	Res. CPR x turns (bit)	CONNECTION
AST58 = single-turn Ø58	H15 = hollow Ø15mm	13x01 = 8192 x 1	C15 = cable 1.5m
AMT58 = multi-turn Ø58	S06 = solid Ø6mm	13x12 = 8192 x 4096	M12 = M12 connector
	S10 = solid Ø10mm	13x14 = 8192 x 16384	M23 = M23 connector
		16x14 = 65536 x 16384	Fbus = modular Fieldbus*
			CB = integrated CANopen
			DN = integrated Devicenet
			EC = integrated Ethercat
			PB = integrated Profibus
			PN = integrated Profinet

\*Fieldbus interface modules available for CANopen®, Devicenet, Profibus DP.

### SINGLE-TURN - SSI®

#### AST58

# AST58



Power supply	7.5-34 Vdc		
Resolution	13 bit = up to 8192 count per revolution (CPR)		
Output code	GRAY		
Output circuit	Serial Synchronous Interface SSI®		
Connection	cable 1.5m or connector M12 or M23		
Case diameter	Ø 58 mm		
Case material	anticorodal aluminium, UNI EN AW-6082		
Flange material	anticorodal aluminium, UNI EN AW-6082		
Shaft material	stainless steel, non-magnetic - UNI EN 4305		
Shaft type	hollow shaft	solid shaft	
Shaft diameter	o Ø 15 mm	• Ø 6 mm	• Ø 10 mm
Single-turn / cable	AST58-H15-13x01-C15	AST58-S06-13x01-C15	AST58-S10-13x01-C15
Single-turn / m12	AST58-H15-13x01-M12	AST58-S06-13x01-M12	AST58-S10-13x01-M12
Single-turn / m23	AST58-H15-13x01-M23	AST58-S06-13x01-M23	AST58-S10-13x01-M23

MULTI-TURN - SSI®

AMT58

# AMT58



Power supply	7.5-34 Vdc		
Resolution	13 x 12 bit = up to 8192 CPR x 4096 turns		
Output code	GRAY		
Output circuit	Serial Synchronous Interface SSI®		
Connection	cable 1.5m or connector M12 or M23		
Case diameter	Ø 58 mm		
Case material	anticorrosive aluminium, UNI EN AW-6082		
Flange material	anticorrosive aluminium, UNI EN AW-6082		
Shaft material	stainless steel, non-magnetic - UNI EN 4305		
Shaft type	hollow shaft	solid shaft	
Shaft diameter	o Ø 15 mm	• Ø 6 mm	• Ø 10 mm
Multi-turn / cable	AMT58-H15-13x12-C15	AMT58-S06-13x12-C15	AMT58-S10-13x12-C15
Multi-turn / M12	AMT58-H15-13x12-M12	AMT58-S06-13x12-M12	AMT58-S10-13x12-M12
Multi-turn / M23	AMT58-H15-13x12-M23	AMT58-S06-13x12-M23	AMT58-S10-13x12-M23

MULTI-TURN - FIELDBUS

AMT58 FIELDBUS

# AMT58 FIELDBUS



Power supply	10-30 Vdc		
Resolution	13 x 12 bit / 13 x 14 bit / 16 x 14 bit		
Output circuit	Fieldbus interface module		
Connection	M12 connectors		
Case diameter	Ø 58 mm		
Case material	anticorrosive aluminium, UNI EN AW-6082		
Flange material	anticorrosive aluminium, UNI EN AW-6082		
Shaft material	stainless steel, non-magnetic - UNI EN 4305		
Shaft type	hollow shaft	solid shaft	
Shaft diameter	o Ø 15 mm	• Ø 6 mm	• Ø 10 mm
Encoder base unit*	AMT58-H15-16x14-FBUS	AMT58-S06-16x14-FBUS	AMT58-S10-16x14-FBUS
CANopen® module*	with AMT58-FBUS-CB	with AMT58-FBUS-CB	with AMT58-FBUS-CB
Devicenet module*	with AMT58-FBUS-DN	with AMT58-FBUS-DN	with AMT58-FBUS-DN
Profibus-DP module*	with AMT58-FBUS-PB	with AMT58-FBUS-PB	with AMT58-FBUS-PB
Canopen integrated**	AMT58-H15-13x12-CB	-	AMT58-S10-13x12-CB
Devicenet integrated**	AMT58-H15-13x12-DN	-	AMT58-S10-13x12-DN
Ethercat integrated**	AMT58-H15-13x14-EC	-	AMT58-S10-13x14-EC
Profibus integrated**	AMT58-H15-13x12-PB	-	AMT58-S10-13x12-PB
Profinet integrated**	AMT58-H15-13x14-PN	-	AMT58-S10-13x14-PN

\* The encoder base unit must be ordered with the Fieldbus interface module

\*\* Includes the encoder base unit and the integrated Fieldbus interface

# INCREMENTAL ENCODERS



# INCREMENTAL ENCODERS



# INCREMENTAL ENCODERS

## ENC41™

### Basic Line

- Compact dimension  $\varnothing 41$ mm
- Hollow or solid shaft
- Cost effective
- Light duty



### APPLICATIONS

- Working and assembling lines
- Packaging machinery
- Light conveyors



### MECHANICAL AND ENVIRONMENTAL SPECIFICATIONS

Case dimension	$\varnothing 40.5$ mm, depth 34 mm
Shaft dimension	Hollow or solid shaft $\varnothing 6$ mm
Shaft loading (axial and radial)	20 N max.
Shaft rotational speed	6000 rpm max.
Starting torque at 20 °C	$\leq 0.3$ Ncm (typ.)
Bearings life	$10^9$ min.
Weight	0.1 kg (3.5 oz) ca.
Case material	Fibre glass epoxy resin
Flange material	Aluminium anticorrosional UNI EN AW-6082
Shaft material	Stainless steel non-magnetic UNI EN 4305
Bearings material	ABEC 5
Mechanical protection	IP64
Shock resistance	100g, 6 ms (MIL STD 202F)
Vibration resistance	10 g, 5-2000 Hz (MIL STD 202F)
Operating temperature	-25 to +85°C (-13 to 185°F)
Storage temperature	-25 to +85°C (-13 to 185°F), 98% R.H. non condensing

Note: specifications subject to changes without prior notice, please refer to the user manual received with the product for mounting, wiring and operation.

### ELECTRICAL SPECIFICATIONS

Resolution	100, 360, 500, 1000, 1024, 2048, 4096 PPR
Counting frequency	50 kHz max.
Output signals	AB0 and /A/B/0
Output circuit	Smart Push-Pull & Line Driver
Power supply	5 – 30 Vdc
Consumption	50 mA max.
Output current	40 mA max (per each channel)
Connection	8-poles shielded cable 1.5m (on encoder side)
Protection	Polarity inversion and short circuit
EMC	According to EN61000-6-2 and EN61000-6-4
Light source	Ga-Al diodes
Optoelectronic life	> 100.000 hrs

### ELECTRICAL CONNECTIONS

Signal	A	/A	B	/B	0	/0	+Vdc	0Vdc	Ground
Wire	Green	Yellow	Gray	Pink	Blue	Red	Brown	White	Shield

### DIMENSIONS

#### HOLLOW SHAFT VERSION

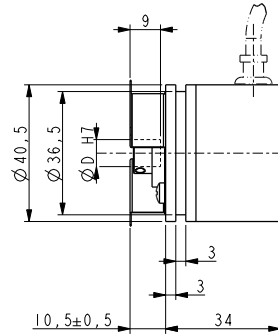
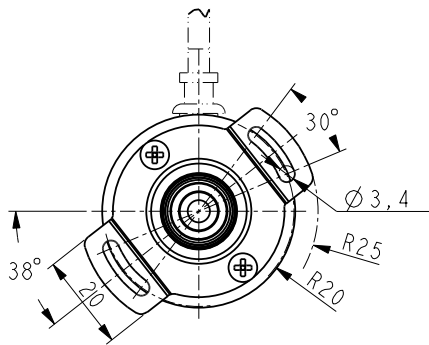

#### SOLID SHAFT VERSION

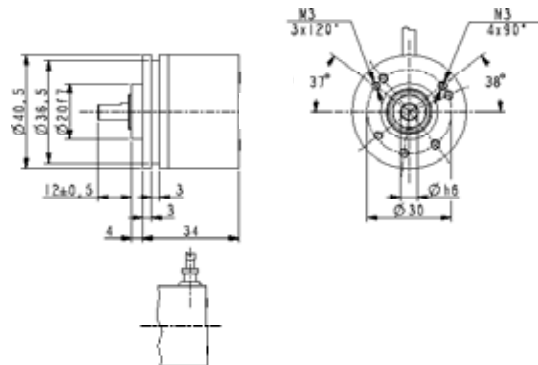
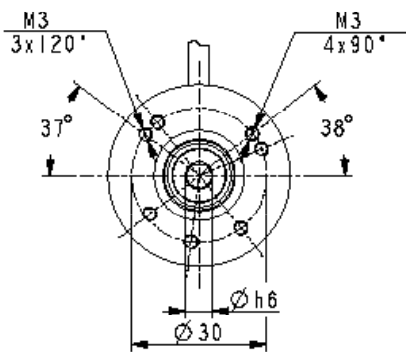

# INCREMENTAL ENCODERS

## Model selection

BASIC LINE MODELS				
SHAFT	CONNECTION	RESOLUTION	MODEL	ORDER NO.
Hollow shaft ○ $\varnothing$ 6 mm	Cable 1.5m	100 PPR	ENC41-H06-0100-C15	95B080070
		360 PPR	ENC41-H06-0360-C15	95B080080
		500 PPR	ENC41-H06-0500-C15	95B080090
		1000 PPR	ENC41-H06-1000-C15	95B080100
		1024 PPR	ENC41-H06-1024-C15	95B080110
		2048 PPR	ENC41-H06-2048-C15	95B080120
		4096 PPR	ENC41-H06-4096-C15	95B080130
Solid shaft ● $\varnothing$ 6 mm	Cable 1.5m	100 PPR	ENC41-S06-0100-C15	95B080000
		360 PPR	ENC41-S06-0360-C15	95B080010
		500 PPR	ENC41-S06-0500-C15	95B080020
		1000 PPR	ENC41-S06-1000-C15	95B080030
		1024 PPR	ENC41-S06-1024-C15	95B080040
		2048 PPR	ENC41-S06-2048-C15	95B080050
		4096 PPR	ENC41-S06-4096-C15	95B080060

ACCESSORIES		
DESCRIPTION	MODEL	ORDER NO.
Flexible Aluminium coupling $\varnothing$ 6 mm	FAC06-06	95B081300
Flexible standard plastic coupling $\varnothing$ 6 mm	FBC06-06	95B081320

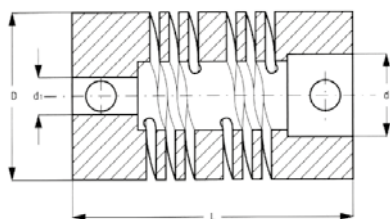

FAC06-06 (L=22/D=19/d=d1=6 mm)

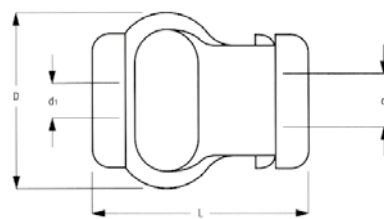

FBC06-06 (L=29/D=22/d=d1=6 mm)



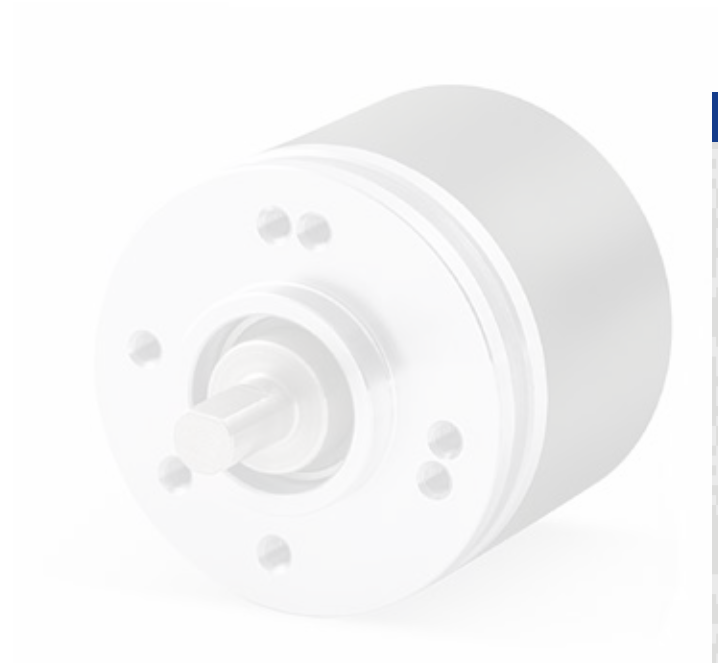
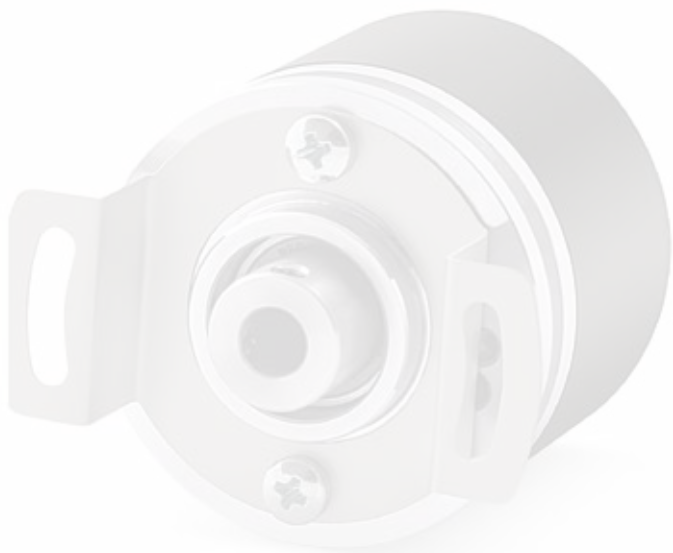

# INCREMENTAL ENCODERS

## ENC58™

### Extended Line

- Standard dimension Ø58mm
- Hollow or solid shaft
- High resolution
- Programmable



### APPLICATIONS

- Motion control
- Automated machinery
- Conveyor lines



### MECHANICAL AND ENVIRONMENTAL SPECIFICATIONS

Case dimension	Ø 58 mm, depth 54 mm
Shaft dimension	Hollow Ø 14 or 15 mm, solid Ø 6 or 10 mm
Shaft loading (axial and radial)	100 N max.
Shaft rotational speed	6000 rpm continuous, 12000 rpm temporary
Starting torque at 20 °C	≤ 1 Ncm (typ.)
Bearings life	10 <sup>9</sup> min.
Weight	0.3 kg (10 oz) ca.
Case material	Aluminium anticorrosional UNI EN AW-6082
Flange material	Aluminium anticorrosional UNI EN AW-6082
Shaft material	Stainless steel non-magnetic UNI EN 4305
Bearings material	ABEC 5
Mechanical protection	IP64
Shock resistance	100g, 6 ms (MIL STD 202F)
Vibration resistance	10 g, 5-2000 Hz (MIL STD 202F)
Operating temperature	-25 to +85°C (-13 to 185°F)
Storage temperature	-25 to +85°C (-13 to 185°F), 98% R.H. non condensing

Note: specifications subject to changes without prior notice, please refer to the user manual received with the product for mounting, wiring and operation.

### ELECTRICAL SPECIFICATIONS

Resolution	500, 1000, 1024, 2000, 2048, 2500, 5000, 10000 PPR and programmable
Counting frequency	100 kHz max.
Output signals	A/B and /A/B/0
Output circuit	Smart Push-Pull & Line Driver
Power supply	5 – 30 Vdc
Consumption	70 mA max.
Output current	40 mA max (per each channel)
Connection	8-poles shielded cable 1.5m or connector M12 or M23
Protection	Polarity inversion and short circuit
EMC	According to EN61000-6-2 and EN61000-6-4
Light source	Ga-Al diodes
Optoelectronic life	> 100.000 hrs

### OUTPUT SIGNALS

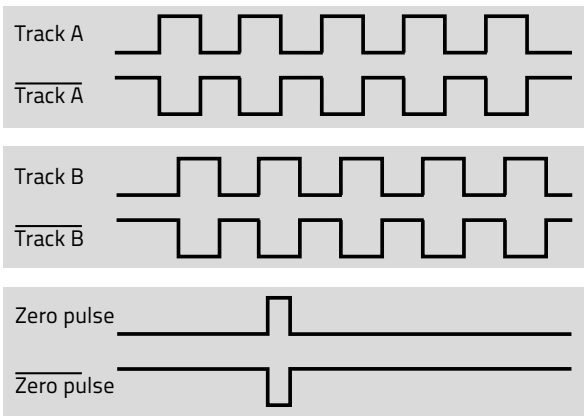

The incremental encoders supply A and B, 90° phase shifted signals, and their related complement outputs.

A single channel can provide the rotation speed only, whereas two phase shifted channels can give also the rotation direction and increase resolution.

The 0 index is used as reference mark for the "home" position.

### ELECTRICAL CONNECTIONS

Signal	A	/A	B	/B	0	/0	+Vdc	0Vdc	Ground
Wire	Green	Yellow	Gray	Pink	Blue	Red	Brown	White	Shield
M12 pin	3	4	5	6	7	8	2	1	Case
M23 pin	3	4	5	6	7	8	2	1	Case

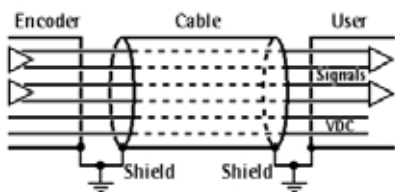

8-poles cable

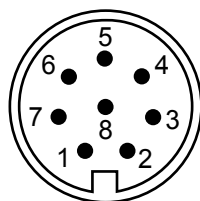

M12 8-pin connector

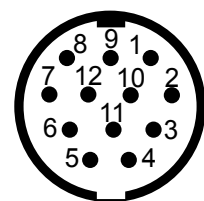

M23 12-pin connector cw  
(only 8 pins are used)

NOTE: view and pin-out of the connectors on the encoder side

# INCREMENTAL ENCODERS

## DIMENSIONS

### HOLLOW SHAFT VERSION

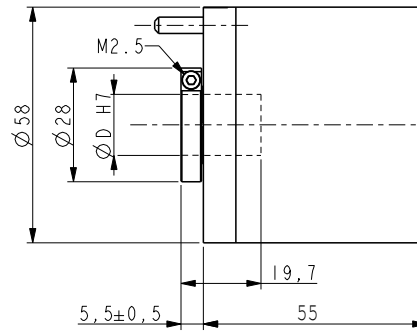
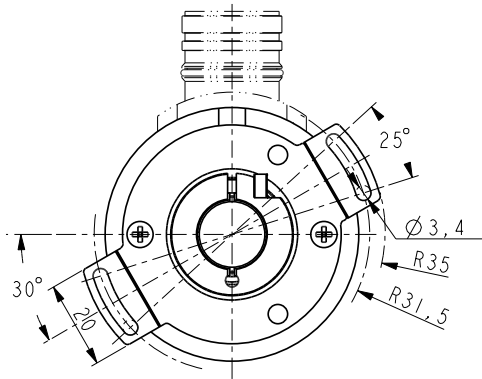

### SOLID SHAFT VERSION

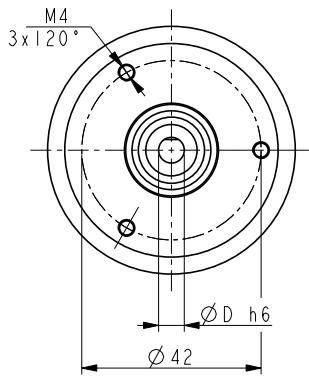

ENC58-S06

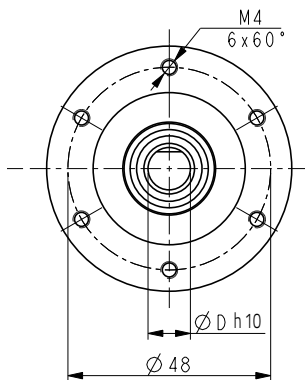
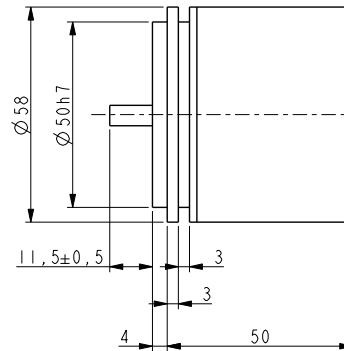

ENC58-S10

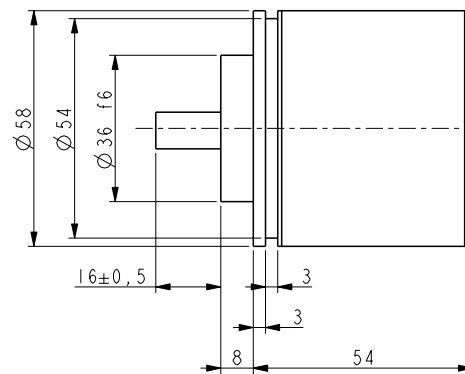

## Model selection

HOLLOW SHAFT MODELS				
SHAFT	CONNECTION	RESOLUTION	MODEL	ORDER NO.
Hollow shaft o $\varnothing$ 14 mm	Cable 1.5m	500 PPR	ENC58-H14-0500-C15	95B080510
		1000 PPR	ENC58-H14-1000-C15	95B080520
		1024 PPR	ENC58-H14-1024-C15	95B080530
		2000 PPR	ENC58-H14-2000-C15	95B080540
		2048 PPR	ENC58-H14-2048-C15	95B080550
		2500 PPR	ENC58-H14-2500-C15	95B081550
		5000 PPR	ENC58-H14-5000-C15	95B080560
		10000 PPR	ENC58-H14-10000-C15	95B080570
	M12 conn.	500 PPR	ENC58-H14-0500-M12	95B080660
		1000 PPR	ENC58-H14-1000-M12	95B080670
		1024 PPR	ENC58-H14-1024-M12	95B080680
		2000 PPR	ENC58-H14-2000-M12	95B080690
		2048 PPR	ENC58-H14-2048-M12	95B080700
		2500 PPR	ENC58-H14-2500-M12	95B081570
		5000 PPR	ENC58-H14-5000-M12	95B080710
		10000 PPR	ENC58-H14-10000-M12	95B080720
	M23 conn.	500 PPR	ENC58-H14-0500-M23	95B080580
		1000 PPR	ENC58-H14-1000-M23	95B080590
		1024 PPR	ENC58-H14-1024-M23	95B080600
		2000 PPR	ENC58-H14-2000-M23	95B080610
		2048 PPR	ENC58-H14-2048-M23	95B081560
		2500 PPR	ENC58-H14-2500-M23	95B080620
		5000 PPR	ENC58-H14-5000-M23	95B080630
		10000 PPR	ENC58-H14-10000-M23	95B080640
Programmable	ENC58-H14-PROG-M23	95B080650		
Hollow shaft o $\varnothing$ 15 mm	Cable 1.5m	500 PPR	ENC58-H15-0500-C15	95B080740
		1000 PPR	ENC58-H15-1000-C15	95B080750
		1024 PPR	ENC58-H15-1024-C15	95B080760
		2000 PPR	ENC58-H15-2000-C15	95B080770
		2048 PPR	ENC58-H15-2048-C15	95B080780
		2500 PPR	ENC58-H15-2500-C15	95B081580
		5000 PPR	ENC58-H15-5000-C15	95B080790
		10000 PPR	ENC58-H15-10000-C15	95B080800
	M12 conn.	500 PPR	ENC58-H15-0500-M12	95B080890
		1000 PPR	ENC58-H15-1000-M12	95B080900
		1024 PPR	ENC58-H15-1024-M12	95B080910
		2000 PPR	ENC58-H15-2000-M12	95B080920
		2048 PPR	ENC58-H15-2048-M12	95B080930
		2500 PPR	ENC58-H15-2500-M12	95B081600
		5000 PPR	ENC58-H15-5000-M12	95B080940
		10000 PPR	ENC58-H15-10000-M12	95B080950
	M23 conn.	500 PPR	ENC58-H15-0500-M23	95B080810
		1000 PPR	ENC58-H15-1000-M23	95B080820
		1024 PPR	ENC58-H15-1024-M23	95B080830
		2000 PPR	ENC58-H15-2000-M23	95B080840
		2048 PPR	ENC58-H15-2048-M23	95B080850
		2500 PPR	ENC58-H15-2500-M23	95B081590
		5000 PPR	ENC58-H15-5000-M23	95B080860
		10000 PPR	ENC58-H15-10000-M23	95B080870
Programmable	ENC58-H15-PROG-M23	95B080880		

# INCREMENTAL ENCODERS

SOLID SHAFT MODELS				
SHAFT	CONNECTION	RESOLUTION	MODEL	ORDER NO.
Solid shaft • Ø6 mm	Cable 1.5m	500 PPR	ENC58-S06-0500-C15	95B080140
		1000 PPR	ENC58-S06-1000-C15	95B080150
		1024 PPR	ENC58-S06-1024-C15	95B080160
		2000 PPR	ENC58-S06-2000-C15	95B080170
		2048 PPR	ENC58-S06-2048-C15	95B080180
		2500 PPR	ENC58-S06-2500-C15	95B081500
		5000 PPR	ENC58-S06-5000-C15	95B080190
		10000 PPR	ENC58-S06-10000-C15	95B080200
	M23 conn.	500 PPR	ENC58-S06-0500-M23	95B080210
		1000 PPR	ENC58-S06-1000-M23	95B080220
		1024 PPR	ENC58-S06-1024-M23	95B080230
		2000 PPR	ENC58-S06-2000-M23	95B080240
		2048 PPR	ENC58-S06-2048-M23	95B080250
		2500 PPR	ENC58-S06-2500-M23	95B081510
		5000 PPR	ENC58-S06-5000-M23	95B080260
		10000 PPR	ENC58-S06-10000-M23	95B080270
Solid shaft • Ø10 mm	Cable 1.5m	500 PPR	ENC58-S10-0500-C15	95B080280
		1000 PPR	ENC58-S10-1000-C15	95B080290
		1024 PPR	ENC58-S10-1024-C15	95B080300
		2000 PPR	ENC58-S10-2000-C15	95B080310
		2048 PPR	ENC58-S10-2048-C15	95B080320
		2500 PPR	ENC58-S10-2500-C15	95B081520
		5000 PPR	ENC58-S10-5000-C15	95B080330
		10000 PPR	ENC58-S10-10000-C15	95B080340
	M12 conn.	500 PPR	ENC58-S10-0500-M12	95B080430
		1000 PPR	ENC58-S10-1000-M12	95B080440
		1024 PPR	ENC58-S10-1024-M12	95B080450
		2000 PPR	ENC58-S10-2000-M12	95B080460
		2048 PPR	ENC58-S10-2048-M12	95B080470
		2500 PPR	ENC58-S10-2500-M12	95B081540
		5000 PPR	ENC58-S10-5000-M12	95B080480
		10000 PPR	ENC58-S10-10000-M12	95B080490
	M23 conn.	500 PPR	ENC58-S10-0500-M23	95B080350
		1000 PPR	ENC58-S10-1000-M23	95B080360
		1024 PPR	ENC58-S10-1024-M23	95B080370
		2000 PPR	ENC58-S10-2000-M23	95B080380
		2048 PPR	ENC58-S10-2048-M23	95B080390
		2500 PPR	ENC58-S10-2500-M23	95B081530
		5000 PPR	ENC58-S10-5000-M23	95B080400
		10000 PPR	ENC58-S10-10000-M23	95B080410
	Programmable	ENC58-S10-PROG-M23	95B080420	

ACCESSORIES		
DESCRIPTION	MODEL	ORDER NO.
Flexible Aluminium coupling Ø6 mm	FAC06-06	95B081300
Flexible Aluminium coupling Ø10 mm	FAC10-10	95B081310
Flexible standard plastic coupling Ø6 mm	FBC06-06	95B081320
Flexible standard plastic coupling Ø10 mm	FBC10-10	95B081330
Encoder reducing sleeve Ø15 - 6 mm	RS15-06	95B081340
Encoder reducing sleeve Ø15 - 8 mm	RS15-08	95B081350
Encoder reducing sleeve Ø15 - 10 mm	RS15-10	95B081360
Encoder reducing sleeve Ø15 - 11 mm	RS15-11	95B081370
Encoder reducing sleeve Ø15 - 12 mm	RS15-12	95B081380
Encoder reducing sleeve Ø15 - 9.52 mm (3/8")	RS15-3/8	95B081390
Ø58 Encoder fixing clamps (3 kits)	ST-58-KIT	95B081400
Ø58 Encoder mounting bell	ST-58-BELL	95B081410
Ø58 Encoder mounting L-bracket	ST-58-BRKT	95B081420
Ø58 Encoder mounting square flange	ST-58-FLNG	95B081430
Incremental encoder conn. cw M23 12-poles with 5m cable	CN-M23-12P-05	95B081260
Incremental encoder conn. cw M23 12-poles with 10m cable	CN-M23-12P-10	95B081270
Incremental encoder conn. cw M23 12-poles without cable	CN-M23-12P-00	95B081280
Metal M12 8-poles female conn. with 5m cable	CN-M12-08P-05	95B081230
Metal M12 8-poles female conn. with 10m cable	CN-M12-08P-10	95B081240
Metal M12 8-poles female connector without cable	CN-M12-08P-00	95B081250
UL Plastic M12 8-poles female conn. with 3m cable	CS-A1-06-U-03	95ASE1170
UL Plastic M12 8-poles female conn. with 5m cable	CS-A1-06-U-05	95ASE1180
UL Plastic M12 8-poles female conn. with 10m cable	CS-A1-06-U-10	95ASE1190
UL Plastic M12 8-poles female conn. with 15m cable	CS-A1-06-U-15	95ASE1200
UL Plastic M12 8-poles female conn. with 25m cable	CS-A1-06-U-25	95ASE1210
UL Plastic M12 8-poles female conn. with 50m cable	CS-A1-06-U-50	95A252700
UL Plastic M12 8-poles female connector without cable	CS-A1-06-B-NC	95ACC2550
USB KIT for programmable encoders	ENC58-PROG-KIT	95B081760

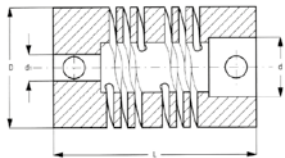

FAC06-06 (L22/D19/d6 mm)  
FAC10-10 (L24/D25/d10 mm)

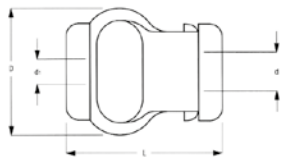

FBC06-06 (L29/D22/d6 mm)  
FBC10-10 (L29/D22/d10 mm)

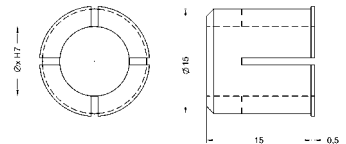

RS15-xx (int. Ø as specified in description)

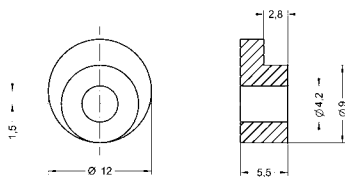

ST58-KIT

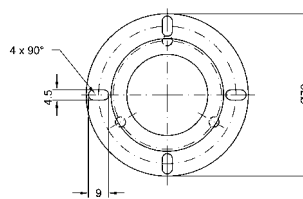

ST58-BELL

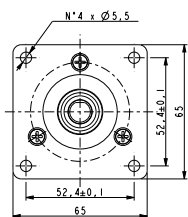
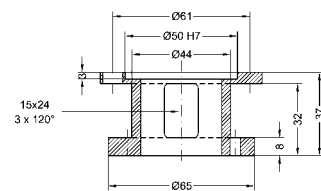

ST58-FLNG

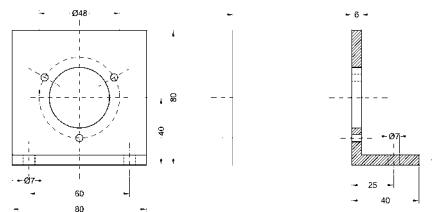

ST58-BRKT

# INCREMENTAL ENCODERS

## IEP58™

### Programmable Line

- Standard dimension Ø58mm
- Hollow or solid shaft
- High resolution up to 16384 PPR
- Programmable via USB cable
- Magnetic Encoder Technology



#### APPLICATIONS

- Motion control
- Automated machinery
- Conveyor lines



#### MECHANICAL AND ENVIRONMENTAL SPECIFICATIONS

Case dimension	Ø 58 mm, depth 54 mm
Shaft dimension	Hollow Ø 14 or 15 mm, solid Ø 6, 8 or 10 mm
Shaft loading (axial and radial)	100 N max.
Shaft rotational speed	6000 rpm continuous, 12000 rpm temporary
Starting torque at 20 °C	0,15 Ncm (S06); 0,4 Ncm (S08/S10/H14/H15)
Bearings life	400 x 10 <sup>6</sup> rev. min. (10 <sup>9</sup> rev. min. with 20 N shaft loading max.)
Weight	0.2 kg (7 oz) ca.
Case material	Aluminium anticorrosive UNI EN AW-6082
Flange material	Aluminium anticorrosive UNI EN AW-6082
Shaft material	Stainless steel non-magnetic UNI EN 4305
Bearings material	ABEC 5
Mechanical protection	IP65
Shock resistance	100g, 6 ms (MIL STD 202F)
Vibration resistance	10 g, 5-2000 Hz (MIL STD 202F)
Operating temperature	-40 to +85 °C (-40 to 185 °F)
Storage temperature	-40 to +100 °C (-40 to 212 °F), 98% R.H. non condensing

Note: specifications subject to changes without prior notice, please refer to the user manual received with the product for mounting, wiring and operation.



## ELECTRICAL SPECIFICATIONS

Resolution	Programmable from 1 to 16384 PPR
Accuracy	± 0.05°
Counting frequency	500 kHz max.
Output signals	AB0 and /A/B/0
Output circuit	Smart Push-Pull & Line Driver
Power supply	5 – 30 Vdc
Consumption	60 mA max.
Output current	40 mA max (per each channel)
Connection	12-poles shielded cable 1.5m or connector M12 or M23
Protection	Polarity inversion and short circuit
EMC	According to EN61000-4-2 and EN61000-4-4
Light source	Ga-Al diodes
Optoelectronic life	> 100000 hrs

## OUTPUT AND INPUT SIGNALS

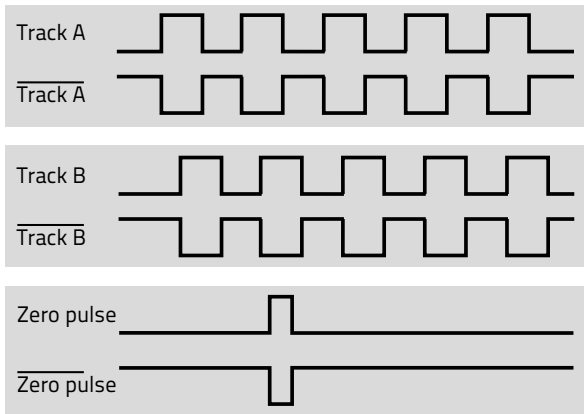

The incremental encoders supply A and B, 90° phase shifted signals, and their related complement outputs.

A single channel can provide the rotation speed only, whereas two phase shifted channels can give also the rotation direction and increase resolution.

The 0 index is used as reference mark for the "home" position.

Index set: the 0 index is selectable for length 90° or 180° electrical.

Count dir.: the count direction is selectable cw or ccw.

SDA: serial data line carries the data bits.

SCL: serial clock line is used for data timing.

## ELECTRICAL CONNECTIONS

Signal	0Vdc	+Vdc	A	/A	B	/B	0	/0	Index set	Count dir.	SDA	SCL	Ground
Wire	White	Brown	Green	Yellow	Gray	Pink	Blue	Red	Black	Violet	Gray/Pink	Red/Blue	Shield
M12 pin	1	2	3	4	5	6	7	8	9	10	11	12	Case
M23 pin	1	2	3	4	5	6	7	8	9	10	11	12	Case

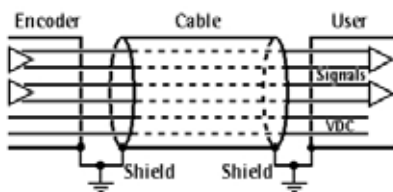

12-poles cable

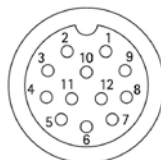

M12 12-pin connector



M23 12-pin cw connector

NOTE: view and pin-out of the connectors on the encoder side

# INCREMENTAL ENCODERS

## DIMENSIONS

### S06 VERSION

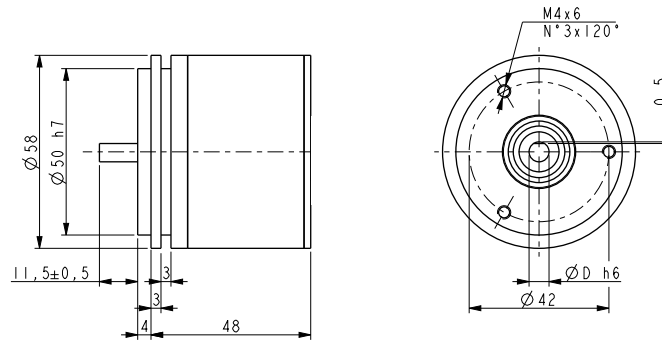

### S08/S10 VERSION

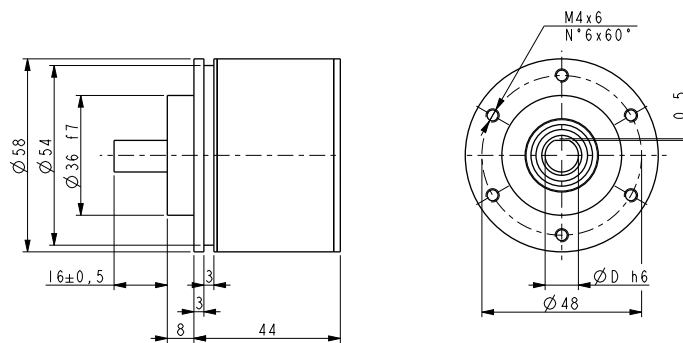

### H14/H15 VERSION

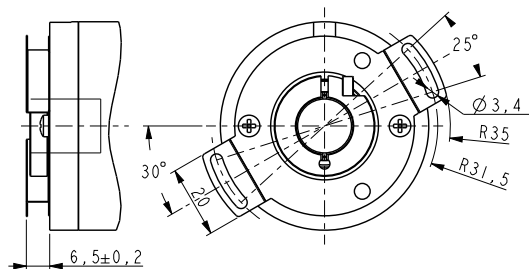

## Model selection

SHAFT	CONNECTION	MODEL	ORDER NO.
Solid shaft • $\varnothing 6$ mm	Cable 1.5 m	IEP58-S06-PROG-C15	95B081830
	M12 conn.	IEP58-S06-PROG-M12	95B081840
	M23 conn.	IEP58-S06-PROG-M23	95B081850
Solid shaft • $\varnothing 8$ mm	Cable 1.5 m	IEP58-S08-PROG-C15	95B081860
	M12 conn.	IEP58-S08-PROG-M12	95B081870
	M23 conn.	IEP58-S08-PROG-M23	95B081880
Solid shaft • $\varnothing 10$ mm	Cable 1.5 m	IEP58-S10-PROG-C15	95B081890
	M12 conn.	IEP58-S10-PROG-M12	95B081900
	M23 conn.	IEP58-S10-PROG-M23	95B081910
Hollow shaft ○ $\varnothing 14$ mm	Cable 1.5 m	IEP58-H14-PROG-C15	95B081920
	M12 conn.	IEP58-H14-PROG-M12	95B081930
	M23 conn.	IEP58-H14-PROG-M23	95B081940
Hollow shaft ○ $\varnothing 15$ mm	Cable 1.5 m	IEP58-H15-PROG-C15	95B081950
	M12 conn.	IEP58-H15-PROG-M12	95B081960
	M23 conn.	IEP58-H15-PROG-M23	95B081970

ACCESSORIES		
DESCRIPTION	MODEL	ORDER NO.
IEP58 PROGRAMMING TOOL	IEP58-PROG-TOOL	95B081980
M23 PROGRAMMING CABLE	CN-M23-PROG CABLE	95B081990
M12 PROGRAMMING CABLE	CN-M12-PROG CABLE	95B082000
Flexible Aluminium coupling Ø6 mm	FAC06-06	95B081300
Flexible Aluminium coupling Ø10 mm	FAC10-10	95B081310
Flexible standard plastic coupling Ø6 mm	FBC06-06	95B081320
Flexible standard plastic coupling Ø10 mm	FBC10-10	95B081330
Encoder reducing sleeve Ø15 - 6 mm	RS15-06	95B081340
Encoder reducing sleeve Ø15 - 8 mm	RS15-08	95B081350
Encoder reducing sleeve Ø15 - 10 mm	RS15-10	95B081360
Encoder reducing sleeve Ø15 - 11 mm	RS15-11	95B081370
Encoder reducing sleeve Ø15 - 12 mm	RS15-12	95B081380
Encoder reducing sleeve Ø15 - 9.52 mm (3/8")	RS15-3/8	95B081390
Ø58 Encoder fixing clamps (3 kits)	ST-58-KIT	95B081400
Ø58 Encoder mounting bell	ST-58-BELL	95B081410
Ø58 Encoder mounting L-bracket	ST-58-BRKT	95B081420
Ø58 Encoder mounting square flange	ST-58-FLNG	95B081430
Incremental encoder conn. cw M23 12-poles with 5m cable	CN-M23-12P-05	95B081260
Incremental encoder conn. cw M23 12-poles with 10m cable	CN-M23-12P-10	95B081270
Incremental encoder conn. cw M23 12-poles without cable	CN-M23-12P-00	95B081280
Metal M12 12-poles female conn. with 5m cable	CN-M12-12P-05	95B082010
Metal M12 12-poles female conn. with 10m cable	CN-M12-12P-10	95B082020
Metal M12 12-poles female connector without cable	CN-M12-12P-00	95B082030

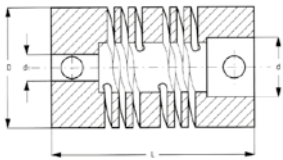

FAC06-06 (L22/D19/d6 mm)  
FAC10-10 (L24/D25/d10 mm)

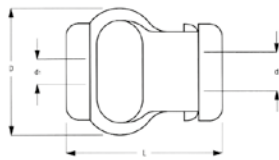

FBC06-06 (L29/D22/d6 mm)  
FBC10-10 (L29/D22/d10 mm)

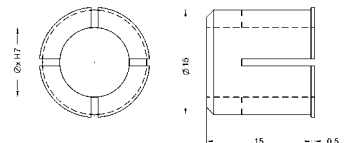

RS15-xx (int. Ø as specified in description)

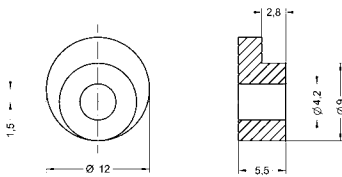

ST58-KIT

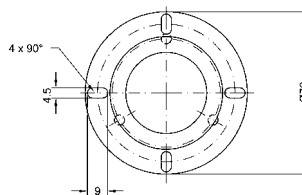

ST-58-BELL

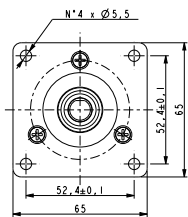
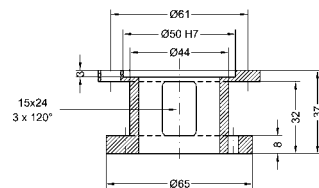

ST-58-FLNG

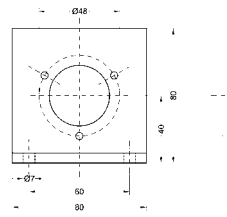

ST-58-BRKT

# INCREMENTAL ENCODERS

## OEK-4™

### Optical Encoder Kit

- Incremental Encoder 250 PPR
- Double Measuring Wheels
- Rotatable Support with Springs
- Standard M12 connector



#### APPLICATION

- Conveyor speed control
- Linear measurement
- Object positioning
- Stop or cut to length



#### ELECTRICAL SPECIFICATIONS

Supply voltage		5-30 Vdc
Supply current		70 mA max. (no load)
Output voltage		High supply voltage – 2.5 Vdc / Low 1.5 Vdc max.
Output current		40 mA max.
Output circuit		NPN PNP Push-pull and Line Driver
Output signal		Single channel A
Output waveform		50/50 square wave with reduced jitter effect
Protection		ESD, reverse voltage and short circuit
Resolution	Vdc	250 pulses per revolution, 1.27mm (0.05") linear resolution
Rotation speed	PNP	6000 rpm max.
	Counting freq.	100 kHz max.
EMC rating	cable	According to EN61000-4-2 and EN61000-4-4
	Light source	Ga-Al diodes (Life > 100000 hrs)
Connection		M12 4-poles

MODEL SELECTION		
DESCRIPTION	MODEL	ORDER No.
Encoder Kit PNP 250PPR M12 + Spring	OEK-4	95B081810

ACCESSORY CABLES		
DESCRIPTION	MODEL	ORDER No.
M12 connector with 3m shielded cable	CV-A1-22-B-03	95ACC1480
M12 connector with 5m shielded cable	CV-A1-22-B-05	95ACC1490
M12 connector with 10m shielded cable	CV-A1-22-B-10	95ACC1500
M12 connector with 15m shielded cable	CV-A1-22-B-15	95ACC2070
M12 connector with 25m shielded cable	CV-A1-22-B-25	95ACC2090

Note: Accessory cables must be ordered separately

MECHANICAL AND ENVIRONMENTAL SPECIFICATIONS		
Kit weight		1 kg
Bearing load		100 N max.
Bearing type		109 min.
Bearing material		ABEC 5
Case material		Zamak die cast
Shaft material		Stainless steel non-magnetic UNI EN 4305
Support material		Aluminium anticorodal UNI EN AW-6082, anodized
Wheel material		Aluminium anticorodal UNI EN AW-6082 with rubber O-ring
Wheel dimension		Ø 101mm, circumference 317.34mm (O-ring included)
Encoder IP rating		IP64
Temperature		-25° to +85°C (operating/storage) 98% rH non condensing

### MECHANICAL DIMENSIONS

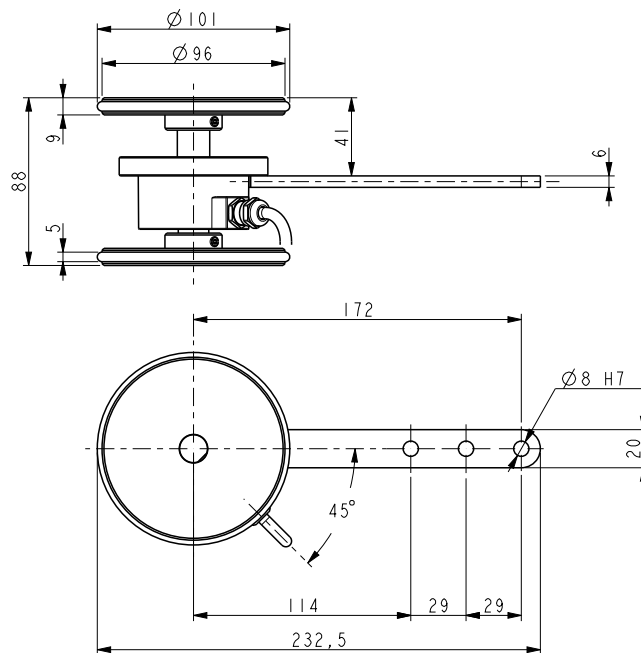

### ELECTRICAL CONNECTIONS

M12 4-poles male connector  
(encoder side view)

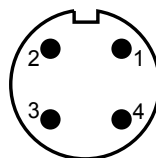

Pin 1 – brown wire: +5: 30Vdc  
 Pin 2 – not connected  
 Pin 3 – blue wire: 0Vdc  
 Pin 4 – black wire: Output A

# ABSOLUTE ENCODERS



# ABSOLUTE ENCODERS



# ABSOLUTE ENCODERS

## AST58™

### SSI® Single-turn Line

- Standard dimension Ø58mm
- Hollow or solid shaft
- High resolution
- High accuracy



#### APPLICATIONS

- Motion control
- Conveyor lines
- Automated machinery



#### MECHANICAL AND ENVIRONMENTAL SPECIFICATIONS

Case dimension	Ø 58 mm, depth 48 mm
Shaft dimension	Hollow Ø 15 mm, solid Ø 6 or 10 mm
Shaft loading (axial and radial)	100 N max.
Shaft rotational speed	9000 rpm continuous, 12000 rpm temporary
Bearings life	400x10 <sup>6</sup> rev. min. (10 <sup>9</sup> rev. min. with shaft loading of 20 N max.)
Weight	0.3 kg (10 oz) ca.
Case material	Aluminium anticorrosive UNI EN AW-6082
Flange material	Aluminium anticorrosive UNI EN AW-6082
Shaft material	Stainless steel non-magnetic UNI EN 4305
Bearings material	ABEC 5
Mechanical protection	IP65
Shock resistance	100g, 6 ms (MIL STD 202F)
Vibration resistance	10 g 5-2000 Hz (MIL STD 202F)
Operating temperature	-25 to +85°C (-13 to 185°F)
Storage temperature	-40 to +100°C (-40 to 212°F), 98% R.H. non condensing

Note: specifications subject to changes without prior notice, please refer to the user manual received with the product for mounting, wiring and operation.



### ELECTRICAL SPECIFICATIONS

Resolution	13 bit = up to 8192 count per revolution (CPR)
Counting frequency	> 150 kHz max.
Accuracy	±0.02°
Output code	GRAY
Output circuit	SSI® (RS422) tree format
Power supply	7.5 – 34 Vdc
Consumption	0.9 W
Input functions	Counting direction and Zero setting/Preset
Connection	8-poles shielded cable 1.5m or connector M12 or M23
Protection	Polarity inversion and short circuit
EMC	According to EN61000-4-2/A1 and EN61000-4-4
Light source	Ga-Al diodes
Optoelectronic life	> 100.000 hrs

### ELECTRICAL CONNECTIONS

SSI®	0 Vdc	+Vdc	Clock in+	Clock in-	Data out+	Data out-	Preset	Direction	Ground
Wire	White	Brown	Green	Yellow	Gray	Pink	Blue	Red	Shield
M12 pin	1	2	3	4	5	6	7	8	Case
M23 pin	1	2	3	4	5	6	7	8	Case

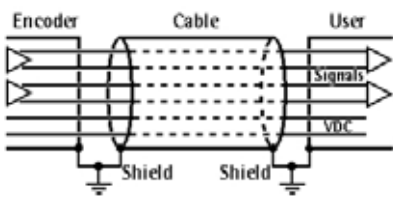

8-poles cable

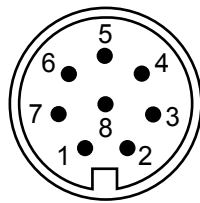

M12 8-pin connector

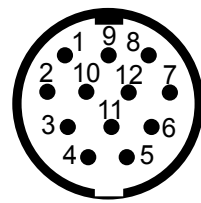

M23 12-pin connector ccw  
(only 8 pins are used)

NOTE: view and pin-out of the connectors on the encoder side

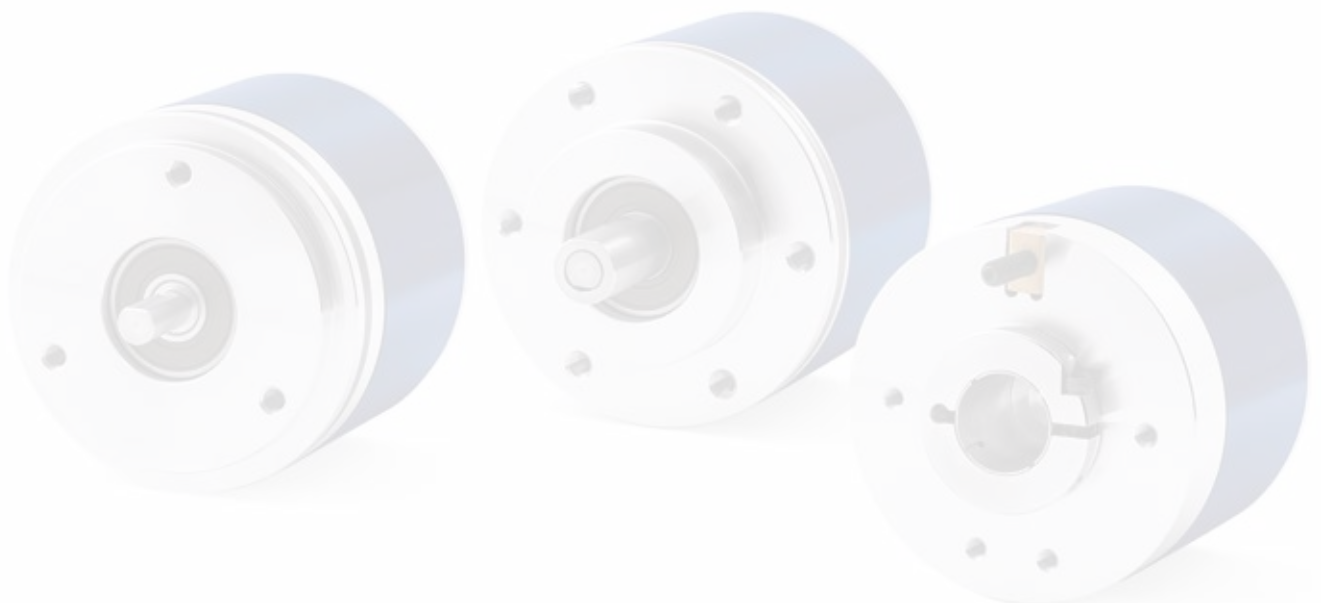

# ABSOLUTE ENCODERS

## DIMENSIONS

### HOLLOW SHAFT VERSION

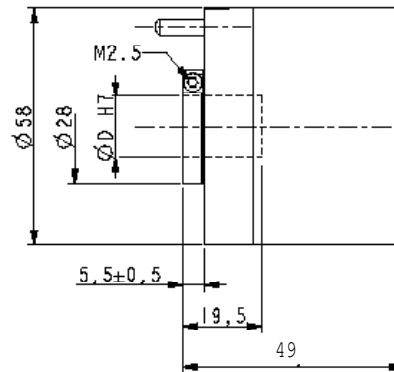
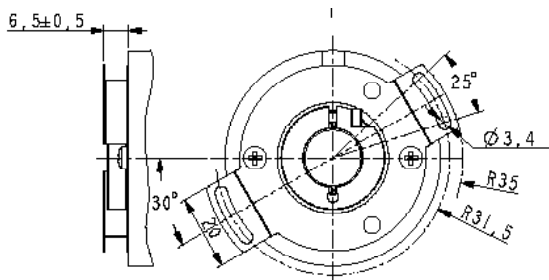

### SOLID SHAFT VERSION

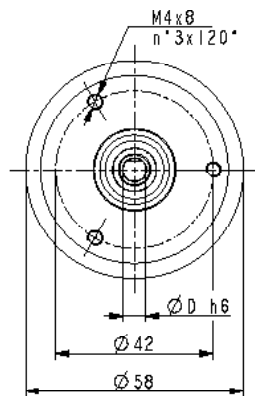

AST58-S06

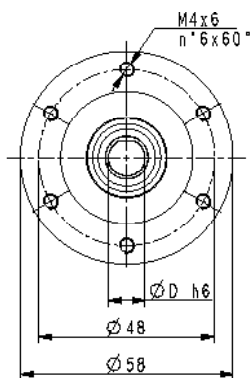
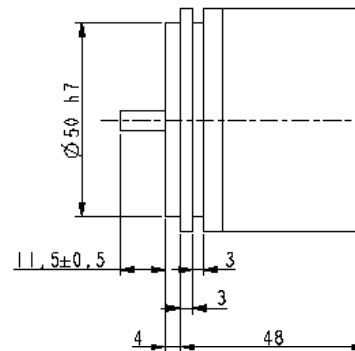

AST58-S10

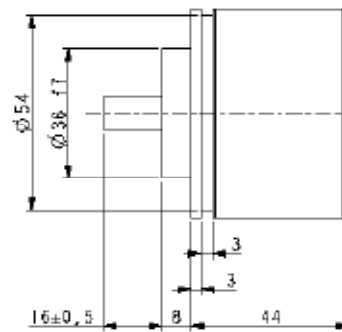

## Model selection

### SSI® SINGLE-TURN MODELS

SHAFT	CONNECTION	MODEL	ORDER NO.
Hollow shaft ○ Ø15 mm	Cable 1.5m	AST58-H15-13x01-C15	95B081050
	M12 conn.	AST58-H15-13x01-M12	95B081030
	M23 conn.	AST58-H15-13x01-M23	95B081040
Solid shaft ● Ø6 mm	Cable 1.5m	AST58-S06-13x01-C15	95B080990
	M12 conn.	AST58-S06-13x01-M12	95B080970
	M23 conn.	AST58-S06-13x01-M23	95B080980
Solid shaft ● Ø10 mm	Cable 1.5m	AST58-S10-13x01-C15	95B081020
	M12 conn.	AST58-S10-13x01-M12	95B081000
	M23 conn.	AST58-S10-13x01-M23	95B081010

ACCESSORIES		
DESCRIPTION	MODEL	ORDER NO.
Flexible Aluminium coupling Ø6 mm	FAC06-06	95B081300
Flexible Aluminium coupling Ø10 mm	FAC10-10	95B081310
Flexible standard plastic coupling Ø6 mm	FBC06-06	95B081320
Flexible standard plastic coupling Ø10 mm	FBC10-10	95B081330
Encoder reducing sleeve Ø15 - 6 mm	RS15-06	95B081340
Encoder reducing sleeve Ø15 - 8 mm	RS15-08	95B081350
Encoder reducing sleeve Ø15 - 10 mm	RS15-10	95B081360
Encoder reducing sleeve Ø15 - 11 mm	RS15-11	95B081370
Encoder reducing sleeve Ø15 - 12 mm	RS15-12	95B081380
Encoder reducing sleeve Ø15 - 9.52 mm (3/8")	RS15-3/8	95B081390
Ø58 Encoder fixing clamps (3 kits)	ST-58-KIT	95B081400
Ø58 Encoder mounting bell	ST-58-BELL	95B081410
Ø58 Encoder mounting L-bracket	ST-58-BRKT	95B081420
Ø58 Encoder mounting square flange	ST-58-FLNG	95B081430
Absolute encoder conn. ccw M23 12-poles with 5m cable	CN-M23A-12P-05	95B081290
Absolute encoder conn. ccw M23 12-poles with 10m cable	CN-M23A-12P-10	95B081450
Absolute encoder conn. ccw M23 12-poles without cable	CN-M23A-12P-00	95B081470
Metal M12 8-poles female conn. with 5m cable	CN-M12-08P-05	95B081230
Metal M12 8-poles female conn. with 10m cable	CN-M12-08P-10	95B081240
Metal M12 8-poles female connector without cable	CN-M12-08P-00	95B081250
UL Plastic M12 8-poles female conn. with 3m cable	CS-A1-06-U-03	95ASE1170
UL Plastic M12 8-poles female conn. with 5m cable	CS-A1-06-U-05	95ASE1180
UL Plastic M12 8-poles female conn. with 10m cable	CS-A1-06-U-10	95ASE1190
UL Plastic M12 8-poles female conn. with 15m cable	CS-A1-06-U-15	95ASE1200
UL Plastic M12 8-poles female conn. with 25m cable	CS-A1-06-U-25	95ASE1210
UL Plastic M12 8-poles female conn. with 50m cable	CS-A1-06-U-50	95A252700
UL Plastic M12 8-poles female connector without cable	CS-A1-06-B-NC	95ACC2550

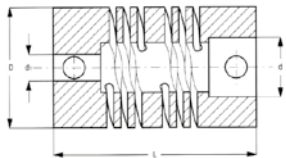

**FAC06-06** (L22/D19/d6 mm)  
**FAC10-10** (L24/D25/d10 mm)

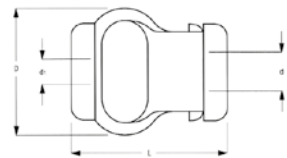

**FBC06-06** (L29/D22/d6 mm)  
**FBC10-10** (L29/D22/d10 mm)

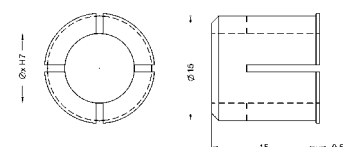

**RS15-xx** (int. Ø as specified in description)

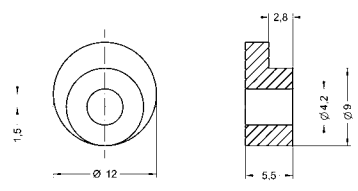

**ST58-KIT**

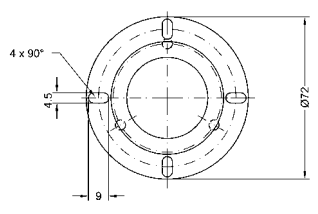

**ST58-BELL**

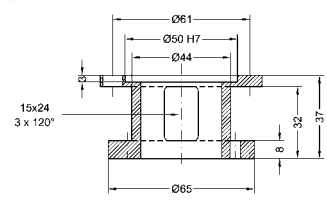

**ST58-BRKT**

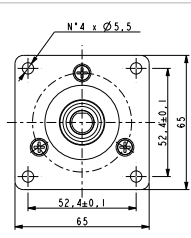

**ST58-FLNG**

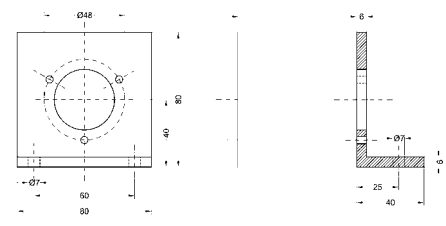

# ABSOLUTE ENCODERS

## AMT58™

### SSI® Multi-turn Line

- Standard dimension Ø58mm
- Hollow or solid shaft
- Very high resolution
- Very high accuracy



#### APPLICATIONS

- Motion control
- Automated machinery
- Length measurement and positioning



#### MECHANICAL AND ENVIRONMENTAL SPECIFICATIONS

Case dimension	Ø 58 mm, depth 48 mm
Shaft dimension	Hollow Ø 15 mm, solid Ø 6 or 10 mm
Shaft loading (axial and radial)	100 N max.
Shaft rotational speed	9000 rpm continuous, 12000 rpm temporary
Bearings life	400x10 <sup>6</sup> rev. min. (10 <sup>9</sup> rev. min. with shaft loading of 20 N max.)
Weight	0.3 kg (10 oz) ca.
Case material	Aluminium anticorrosion UNI EN AW-6082
Flange material	Aluminium anticorrosion UNI EN AW-6082
Shaft material	Stainless steel non-magnetic UNI EN 4305
Bearings material	ABEC 5
Mechanical protection	IP65
Shock resistance	100g, 6 ms (MIL STD 202F)
Vibration resistance	10 g 5-2000 Hz (MIL STD 202F)
Operating temperature	-25 to +85°C (-13 to 185°F)
Storage temperature	-40 to +100°C (-40 to 212°F), 98% R.H. non condensing

Note: specifications subject to changes without prior notice, please refer to the user manual received with the product for mounting, wiring and operation.

### ELECTRICAL SPECIFICATIONS

Resolution	13 x 12 bit = up to 8192 CPR x 4096 turns
Counting frequency	220 kHz max.
Accuracy	±0.007°
Output code	GRAY
Output circuit	SSI® (RS422) tree format
Power supply	7.5 – 34 Vdc
Consumption	1 W
Input functions	Counting direction and Zero setting/Preset
Connection	8-poles shielded cable 1.5m or connector M12 or M23
Protection	Polarity inversion and short circuit
EMC	According to EN61000-4-2/A1 and EN61000-4-4
Light source	Ga-Al diodes
Optoelectronic life	> 100.000 hrs

### ELECTRICAL CONNECTIONS

SSI®	0 Vdc	+Vdc	Clock in+	Clock in-	Data out+	Data out-	Preset	Direction	Ground
Wire	White	Brown	Green	Yellow	Gray	Pink	Blue	Red	Shield
M12 pin	1	2	3	4	5	6	7	8	Case
M23 pin	1	2	3	4	5	6	7	8	Case

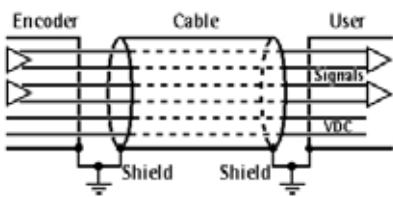

8-poles cable

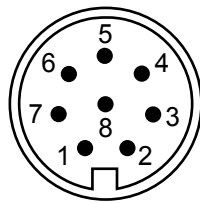

M12 8-pin connector

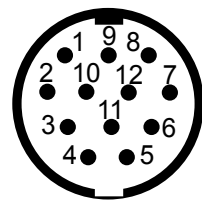

M23 12-pin connector ccw  
(only 8 pins are used)

NOTE: view and pin-out of the connectors on the encoder side

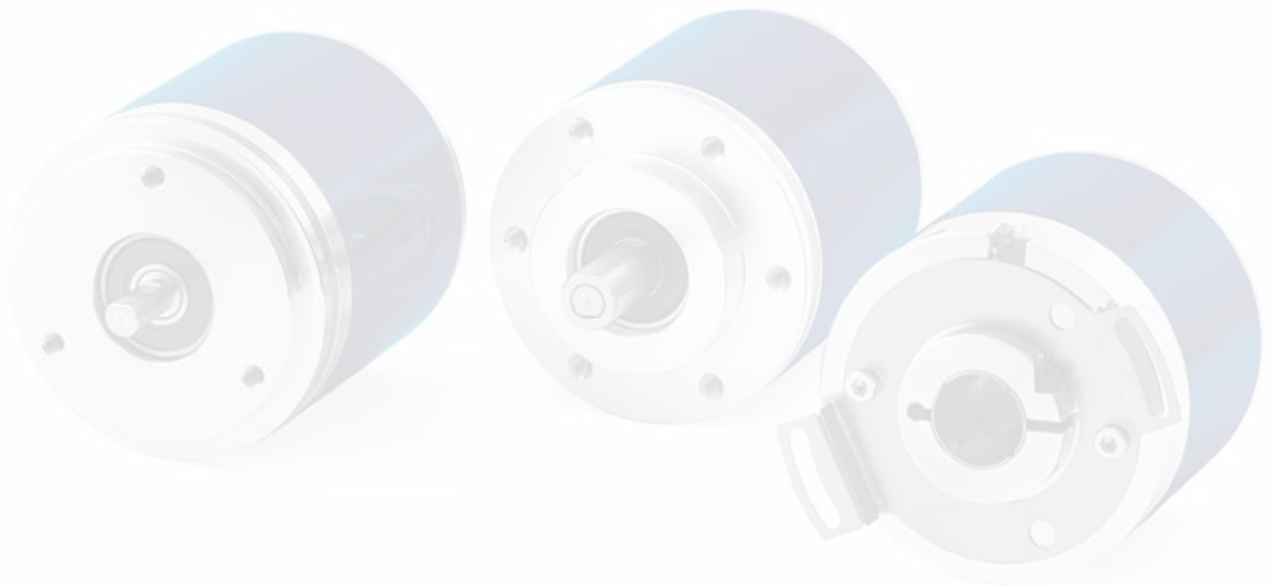

# ABSOLUTE ENCODERS

## DIMENSIONS

### HOLLOW SHAFT VERSION

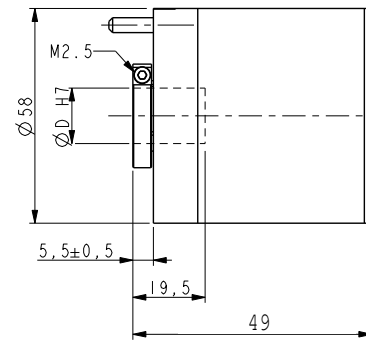
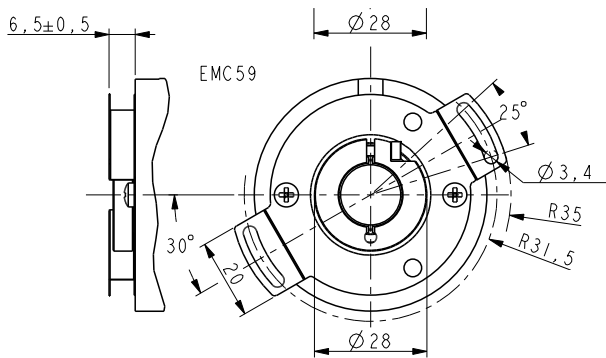

### SOLID SHAFT VERSION

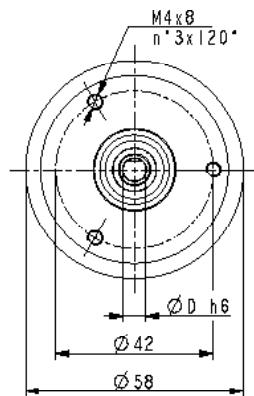

AMT58-S06

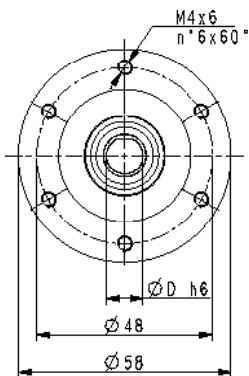
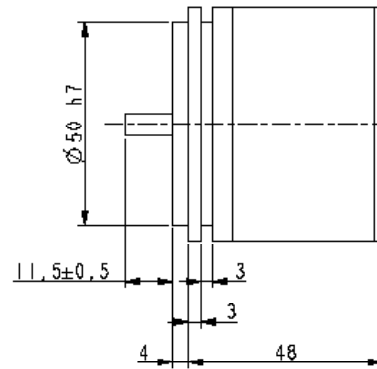

AMT58-S10

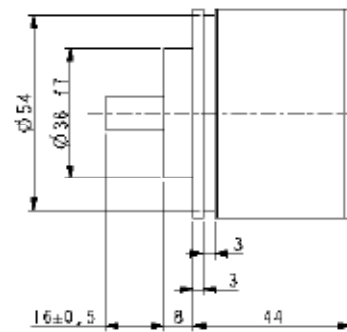

## Model selection

### SSI® MULTI-TURN MODELS

SHAFT	CONNECTION	MODEL	ORDER NO.
Hollow shaft ○ Ø15 mm	Cable 1.5m	AMT58-H15-13x12-C15	95B081140
	M12 conn.	AMT58-H15-13x12-M12	95B081120
	M23 conn.	AMT58-H15-13x12-M23	95B081130
Solid shaft ● Ø6 mm	Cable 1.5m	AMT58-S06-13x12-C15	95B081080
	M12 conn.	AMT58-S06-13x12-M12	95B081060
	M23 conn.	AMT58-S06-13x12-M23	95B081070
Solid shaft ● Ø10 mm	Cable 1.5m	AMT58-S10-13x12-C15	95B081110
	M12 conn.	AMT58-S10-13x12-M12	95B081090
	M23 conn.	AMT58-S10-13x12-M23	95B081100

ACCESSORIES		
DESCRIPTION	MODEL	ORDER NO.
Flexible Aluminium coupling Ø6 mm	FAC06-06	95B081300
Flexible Aluminium coupling Ø10 mm	FAC10-10	95B081310
Flexible standard plastic coupling Ø6 mm	FBC06-06	95B081320
Flexible standard plastic coupling Ø10 mm	FBC10-10	95B081330
Encoder reducing sleeve Ø15 - 6 mm	RS15-06	95B081340
Encoder reducing sleeve Ø15 - 8 mm	RS15-08	95B081350
Encoder reducing sleeve Ø15 - 10 mm	RS15-10	95B081360
Encoder reducing sleeve Ø15 - 11 mm	RS15-11	95B081370
Encoder reducing sleeve Ø15 - 12 mm	RS15-12	95B081380
Encoder reducing sleeve Ø15 - 9.52 mm (3/8")	RS15-3/8	95B081390
Ø58 Encoder fixing clamps (3 kits)	ST-58-KIT	95B081400
Ø58 Encoder mounting bell	ST-58-BELL	95B081410
Ø58 Encoder mounting L-bracket	ST-58-BRKT	95B081420
Ø58 Encoder mounting square flange	ST-58-FLNG	95B081430
Absolute encoder conn. ccw M23 12-poles with 5m cable	CN-M23A-12P-05	95B081290
Absolute encoder conn. ccw M23 12-poles with 10m cable	CN-M23A-12P-10	95B081450
Absolute encoder conn. ccw M23 12-poles without cable	CN-M23A-12P-00	95B081470
Metal M12 8-poles female conn. with 5m cable	CN-M12-08P-05	95B081230
Metal M12 8-poles female conn. with 10m cable	CN-M12-08P-10	95B081240
Metal M12 8-poles female connector without cable	CN-M12-08P-00	95B081250
UL Plastic M12 8-poles female conn. with 3m cable	CS-A1-06-U-03	95ASE1170
UL Plastic M12 8-poles female conn. with 5m cable	CS-A1-06-U-05	95ASE1180
UL Plastic M12 8-poles female conn. with 10m cable	CS-A1-06-U-10	95ASE1190
UL Plastic M12 8-poles female conn. with 15m cable	CS-A1-06-U-15	95ASE1200
UL Plastic M12 8-poles female conn. with 25m cable	CS-A1-06-U-25	95ASE1210
UL Plastic M12 8-poles female conn. with 50m cable	CS-A1-06-U-50	95A252700
UL Plastic M12 8-poles female connector without cable	CS-A1-06-B-NC	95ACC2550

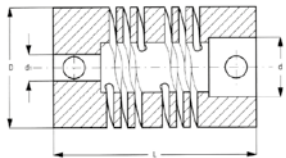

**FAC06-06** (L22/D19/d6 mm)  
**FAC10-10** (L24/D25/d10 mm)

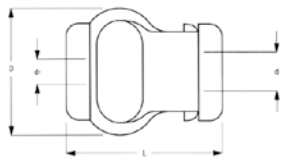

**FBC06-06** (L29/D22/d6 mm)  
**FBC10-10** (L29/D22/d10 mm)

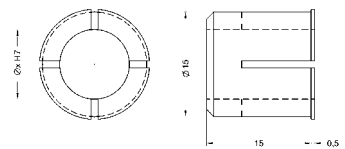

**RS15-xx** (int. Ø as specified in description)

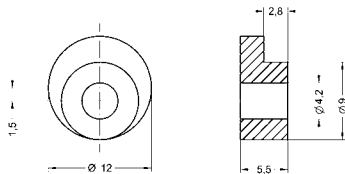

**ST58-KIT**

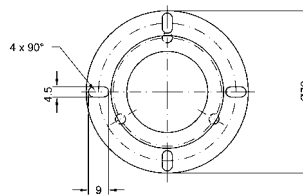

**ST58-BELL**

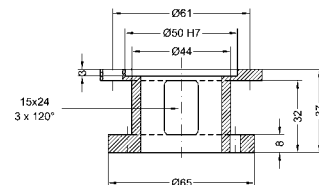

**ST58-BRKT**

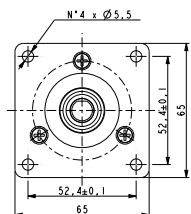

**ST58-FLNG**

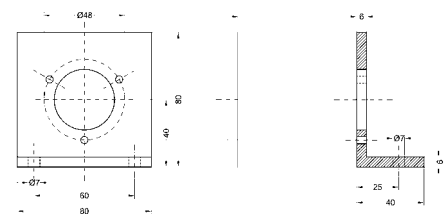

## AMT58™-Modular Fieldbus

*Multi-turn with Modular Fieldbus interface*

- Standard dimension Ø58mm
- Hollow or solid shaft
- Extremely high accuracy
- Modular Fieldbus interface



### APPLICATIONS

- Motion control
- Automated machinery
- Length measurement and positioning



### MECHANICAL AND ENVIRONMENTAL SPECIFICATIONS

Case dimension	Ø 58 mm, depth 71 mm (encoder + interface module)
Shaft dimension	Hollow Ø 15 mm, solid Ø 6 or 10 mm
Shaft loading (axial and radial)	100 N max.
Shaft rotational speed	9000 rpm continuous, 12000 rpm temporary
Bearings life	400x10 <sup>6</sup> rev. min. (10 <sup>9</sup> rev. min. with shaft loading of 20 N max.)
Weight	0.3 kg (10 oz) ca.
Case material	Aluminium anticorrosion UNI EN AW-6082
Flange material	Aluminium anticorrosion UNI EN AW-6082
Shaft material	Stainless steel non-magnetic UNI EN 4305
Bearings material	ABEC 5
Mechanical protection	IP65
Shock resistance	100g, 6 ms (MIL STD 202F)
Vibration resistance	10 g 5-2000 Hz (MIL STD 202F)
Operating temperature	-25 to +85°C (-13 to 185°F)
Storage temperature	-40 to +100°C (-40 to 212°F), 98% R.H. non condensing

Note: specifications subject to changes without prior notice, please refer to the user manual received with the product for mounting, wiring and operation.



## ELECTRICAL SPECIFICATIONS

Resolution	16 x 14 bit = up to 65536 CPR x 16384 turns
Counting frequency	220 kHz max.
Accuracy	±0.007°
Output interface	CANopen®DS310, DS406, DeviceNet, Profibus DP V1
Power supply	7.5 – 34 Vdc
Consumption	2.2 W
Input functions	Counting direction and Zero setting/Preset
Connection	connector M12
Protection	Polarity inversion and short circuit
EMC	EN50081-2, EN50082-2
Light source	Ga-Al diodes
Optoelectronic life	> 100.000 hrs

## ELECTRICAL CONNECTIONS

### CANopen or Devicenet

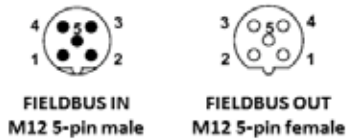

M12 5-pin I/O		
CAN Shield	Case	1
+10...30Vdc	+	2
0Vdc	-	3
CAN High	H	4
CAN Low	L	5

### Profibus-DP



M12 3-pin	
+10...30Vdc	1
0Vdc	3
Shield	4

M12 5-pin I/O		
n.c.		1
Profibus A	Green	2
n.c.		3
Profibus B	Red	4
n.c.		5

NOTE: view and pin-out of the connectors on the encoder side

# ABSOLUTE ENCODERS

## DIMENSIONS

### HOLLOW SHAFT VERSION

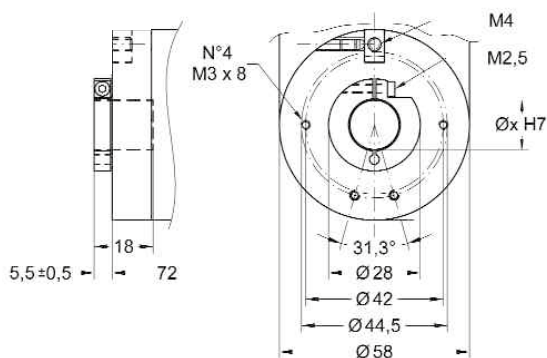

### SOLID SHAFT VERSION

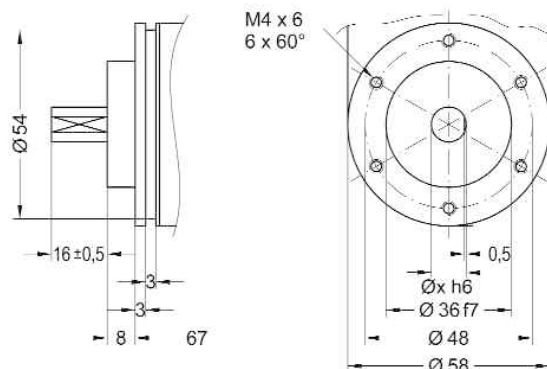

### ENCODER WITH FIELDBUS INTERFACE MODULE

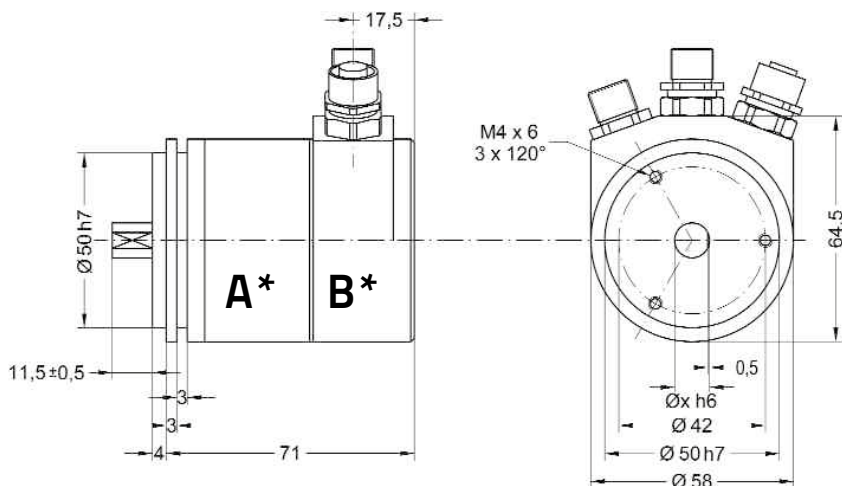

\*The encoder base unit "A" must be connected to the required Fieldbus interface module "B".

### MULTI-TURN BASE MODELS FOR FIELDBUS MODULES

SHAFT	MODEL	ORDER NO.
Encoder base unit with hollow shaft $\varnothing 15$ mm	AMT58-H15-16x14-FBUS	95B081170
Encoder base unit with solid shaft $\bullet \varnothing 6$ mm	AMT58-S06-16x14-FBUS	95B081150
Encoder base unit with solid shaft $\bullet \varnothing 10$ mm	AMT58-S10-16x14-FBUS	95B081160

### FIELDBUS INTERFACE MODULES

FIELDBUS MODULE	MODEL	ORDER NO.
CANopen® interface module*	AMT58-FBUS-CB	95B081190
Devicenet interface module*	AMT58-FBUS-DN	95B081200
Profibus DP interface module*	AMT58-FBUS-PB	95B081180

\* The encoder base unit must be ordered with the Fieldbus interface module

ACCESSORIES

DESCRIPTION	MODEL	ORDER NO.
Flexible Aluminium coupling Ø6 mm	FAC06-06	95B081300
Flexible Aluminium coupling Ø10 mm	FAC10-10	95B081310
Flexible standard plastic coupling Ø6 mm	FBC06-06	95B081320
Flexible standard plastic coupling Ø10 mm	FBC10-10	95B081330
Encoder reducing sleeve Ø15 - 6 mm	RS15-06	95B081340
Encoder reducing sleeve Ø15 - 8 mm	RS15-08	95B081350
Encoder reducing sleeve Ø15 - 10 mm	RS15-10	95B081360
Encoder reducing sleeve Ø15 - 11 mm	RS15-11	95B081370
Encoder reducing sleeve Ø15 - 12 mm	RS15-12	95B081380
Encoder reducing sleeve Ø15 - 9.52 mm (3/8")	RS15-3/8	95B081390
Ø58 Encoder fixing clamps (3 kits)	ST-58-KIT	95B081400
Ø58 Encoder mounting bell	ST-58-BELL	95B081410
Ø58 Encoder mounting L-bracket	ST-58-BRKT	95B081420
Ø58 Encoder mounting square flange	ST-58-FLNG	95B081430
Canopen/Devicenet 2 connectors kit	CN-M12-CB/DN-KIT	95B081690
Canopen/Devicenet output cable	CN-M12-5P-5M-CB/DN-O	95B081700
Canopen/Devicenet input cable	CN-M12-5P-5M-CB/DN-I	95B081710
Profibus 3 connectors kit	CN-M12-PBUS-KIT	95B081720
Profibus power supply cable	CN-M12-4P-5M-BUS-PS	95B081730
Profibus input cable	CN-M12-5P-5M-PBUS-I	95B081740
Profibus output cable	CN-M12-5P-5M-PBUS-O	95B081750

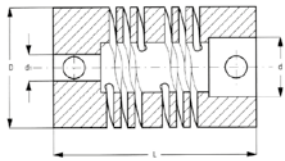

FAC06-06 (L22/D19/d6 mm)  
FAC10-10 (L24/D25/d10 mm)

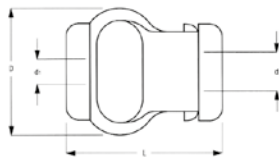

FBC06-06 (L29/D22/d6 mm)  
FBC10-10 (L29/D22/d10 mm)

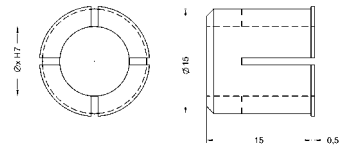

RS15-xx (int. Ø as specified in description)

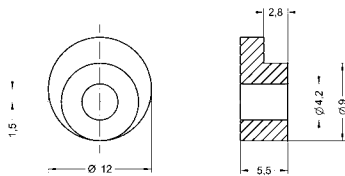

ST58-KIT

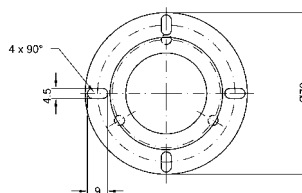

ST-58-BELL

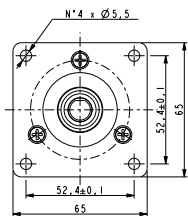
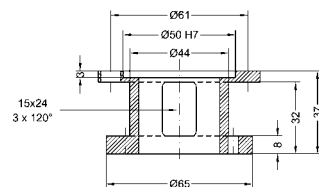

ST-58-FLNG

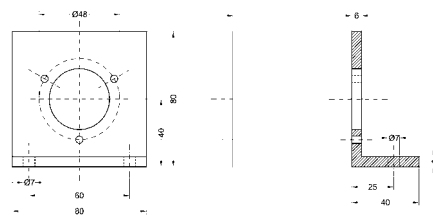

ST-58-BRKT

## AMT58™-Integrated Fieldbus

*Multi-turn with Integrated Fieldbus interface*

- Standard dimension Ø58mm
- Very high resolution
- Extremely high accuracy
- Integrated Fieldbus interface



### APPLICATIONS

- Motion control
- Automated machinery
- Length measurement and positioning



MECHANICAL AND ENVIRONMENTAL SPECIFICATIONS	
Case dimension	Ø 58 mm, depth 71 mm (encoder + interface module)
Shaft dimension	Solid Ø 10 mm
Shaft loading (axial and radial)	100 N max.
Shaft rotational speed	9000 rpm continuous, 12000 rpm temporary
Bearings life	400x10 <sup>6</sup> rev. min. (10 <sup>9</sup> rev. min. with shaft loading of 20 N max.)
Weight	0.3 kg (10 oz) ca.
Case material	Aluminium anticorrosion UNI EN AW-6082
Flange material	Aluminium anticorrosion UNI EN AW-6082
Shaft material	Stainless steel non-magnetic UNI EN 4305
Bearings material	ABEC 5
Mechanical protection	IP65
Shock resistance	100g, 6 ms (MIL STD 202F)
Vibration resistance	10 g 5-2000 Hz (MIL STD 202F)
Operating temperature	-25 to +85°C (-13 to 185°F)
Storage temperature	-40 to +100°C (-40 to 212°F), 98% R.H. non condensing

Note: specifications subject to changes without prior notice, please refer to the user manual received with the product for mounting, wiring and operation.

## ELECTRICAL SPECIFICATIONS

Resolution	13 x 12 bit = 8192 CPR x 4096 turns / 13 x 14 bit = 8192 CPR x 16384 turns
Counting frequency	220 kHz max.
Accuracy	±0.007°
Output interface	Canopen, Devicenet, Ethercat, Profibus, Profinet
Power supply	7.5 – 34 Vdc
Consumption	2.2 W
Input functions	Counting direction and Zero setting/Preset
Connection	connector M12
Protection	Polarity inversion and short circuit
EMC	EN50081-2, EN50082-2
Light source	Ga-Al diodes
Optoelectronic life	> 100.000 hrs

## ELECTRICAL CONNECTIONS

### CANopen or Devicenet



M12 5-pin I/O		
CAN Shield	Case	1
+10...30Vdc	+	2
0Vdc	-	3
CAN High	H	4
CAN Low	L	5

### Profibus-DP



M12 3-pin	
+10...30Vdc	1
0Vdc	3
Shield	4

M12 5-pin I/O		
n.c.		1
Profibus A	Green	2
n.c.		3
Profibus B	Red	4
n.c.		5

### EtherCAT



M12 4-pin PS	
+10...30Vdc	1
n.c.	2
0Vdc	3
n.c.	4

M12 4-pin I/O	
TX Data +	1
RX Data +	2
TX Data -	3
RX Data -	4

### Profinet



M12 4-pin P1	
TX Data +	1
RX Data +	2
TX Data -	3
RX Data -	4

M12 4-pin PS	
+10...30Vdc	1
n.c.	2
0Vdc	3
n.c.	4

M12 4-pin P2	
TX Data +	1
RX Data +	2
TX Data -	3
RX Data -	4

NOTE: view and pin-out of the connectors on the encoder side

# ABSOLUTE ENCODERS

## DIMENSIONS

### ENCODER WITH INTEGRATED FIELDBUS INTERFACE

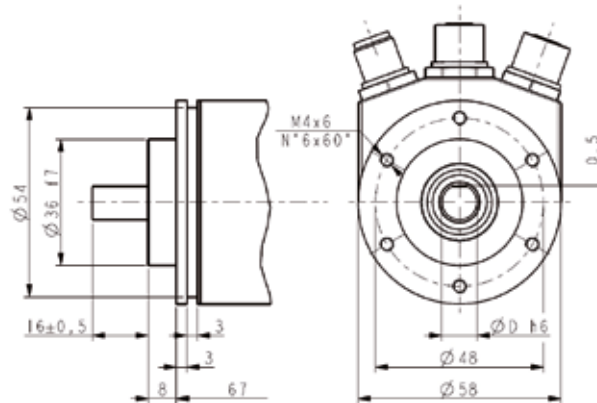

## Model selection

INTEGRATED FIELDBUS MODELS					
SHAFT	CONNECTION	INTERFACE	RESOLUTION	MODEL	ORDER NO.
Solid shaft Ø10 mm	M12	Canopen	13x12 bit	AMT58-S10-13x12-CB	95B081630
Hollow shaft Ø15 mm	M12	Canopen	13x12 bit	AMT58-H15-13x12-CB	95B081640
Solid shaft Ø10 mm	M12	Devicenet	13x12 bit	AMT58-S10-13x12-DN	95B081650
Hollow shaft Ø15 mm	M12	Devicenet	13x12 bit	AMT58-H15-13x12-DN	95B081660
Solid shaft Ø10 mm	M12	Ethercat	13x14 bit	AMT58-S10-13x14-EC	95B081220
Hollow shaft Ø15 mm	M12	Ethercat	13x14 bit	AMT58-H15-13x14-EC	95B081680
Solid shaft Ø10 mm	M12	Profibus	13x12 bit	AMT58-S10-13x12-PB	95B081610
Hollow shaft Ø15 mm	M12	Profibus	13x12 bit	AMT58-H15-13x12-PB	95B081620
Solid shaft Ø10 mm	M12	Profinet	13x14 bit	AMT58-S10-13x14-PN	95B081210
Hollow shaft Ø15 mm	M12	Profinet	13x14 bit	AMT58-H15-13x14-PN	95B081670

ACCESSORIES		
DESCRIPTION	MODEL	ORDER NO.
Flexible Aluminium coupling Ø6 mm	FAC06-06	95B081300
Flexible Aluminium coupling Ø10 mm	FAC10-10	95B081310
Flexible standard plastic coupling Ø6 mm	FBC06-06	95B081320
Flexible standard plastic coupling Ø10 mm	FBC10-10	95B081330
Encoder reducing sleeve Ø15 - 6 mm	RS15-06	95B081340
Encoder reducing sleeve Ø15 - 8 mm	RS15-08	95B081350
Encoder reducing sleeve Ø15 - 10 mm	RS15-10	95B081360
Encoder reducing sleeve Ø15 - 11 mm	RS15-11	95B081370
Encoder reducing sleeve Ø15 - 12 mm	RS15-12	95B081380
Encoder reducing sleeve Ø15 - 9.52 mm (3/8")	RS15-3/8	95B081390
Ø58 Encoder fixing clamps (3 kits)	ST-58-KIT	95B081400
Ø58 Encoder mounting bell	ST-58-BELL	95B081410
Ø58 Encoder mounting L-bracket	ST-58-BRKT	95B081420
Ø58 Encoder mounting square flange	ST-58-FLNG	95B081430
Canopen/Devicenet 2 connectors kit	CN-M12-CB/DN-KIT	95B081690
Canopen/Devicenet output cable	CN-M12-5P-5M-CB/DN-O	95B081700
Canopen/Devicenet input cable	CN-M12-5P-5M-CB/DN-I	95B081710
Profibus 3 connectors kit	CN-M12-PBUS-KIT	95B081720
Ecat/Pbus/Pnet power supply cable	CN-M12-4P-5M-BUS-PS	95B081730
Profibus input cable	CN-M12-5P-5M-PBUS-I	95B081740
Profibus output cable	CN-M12-5P-5M-PBUS-O	95B081750
Ethercat/Profinet programming cable	CN-M12-4P-5M-EC/PN-RJ	95B081770
Ethercat/Profinet input-output cable	CN-M12-4P-5M-EC/PN-IO	95B081780
Ethercat/Profinet input-output plug	CN-M12-4P-00-EC/PN-IO	95B081790

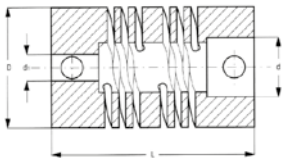

FAC06-06 (L22/D19/d6 mm)  
FAC10-10 (L24/D25/d10 mm)

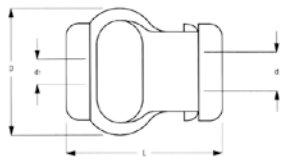

FBC06-06 (L29/D22/d6 mm)  
FBC10-10 (L29/D22/d10 mm)

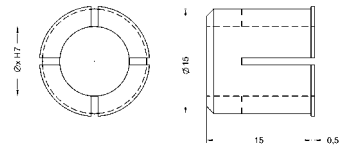

RS15-xx (int. Ø as specified in description)

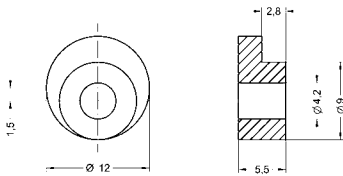

ST58-KIT

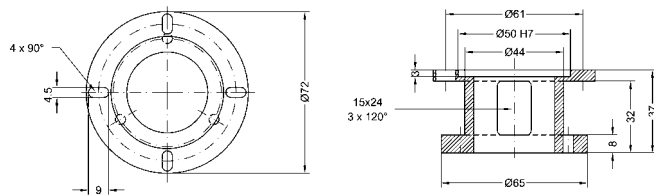

ST-58-BELL

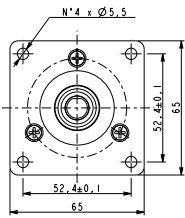

ST-58-FLNG

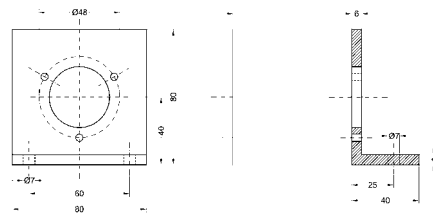

ST-58-BRKT



# LINEAR MEASUREMENT ACCESSORIES





# LINEAR MEASUREMENT ACCESSORIES



# LINEAR MEASUREMENT ACCESSORIES

## DW™

### Draw Wire

The draw wire accessory is used with the encoder for length measurement and position control applications.

The accuracy is given by the ratio between the draw wire drum circumference and the encoder resolution, e.g.:

204.8 mm / 8192 CPR = 0.025 mm per code

200 mm / 10000 PPR = 0.02 mm per pulse



#### APPLICATION

-Length measurement and positioning



#### MECHANICAL AND ENVIRONMENTAL SPECIFICATIONS

Stroke per turn (absolute encoder)	204.8 mm
Stroke per turn (integral encoder)	200 mm
Wire retraction force	5 ± 15 N
Measuring wire length	5000 mm
Measuring speed	3 m/sec max.
Repeat accuracy	± 0.15 mm
Wire material	Stainless steel non-magnetic UNI EN 4305
Housing material	Aluminium anticorodal UNI EN AW-6082
Mechanical protection	IP64
Weight	600 gr. (without encoder)
Operating temperature	-25 to +85°C (-13 to 185°F)
Storage temperature	-25 to +85°C (-13 to 185°F), 98% R.H. non condensing
Shock resistance	100g, 6 ms (MIL STD 202F)
Vibration resistance	10 g, 5-2000 Hz (MIL STD 202F)
Operating temperature	-25 to +85°C (-13 to 185°F)
Storage temperature	-40 to +100°C (-40 to 212°F), 98% R.H. non condensing

MODEL SELECTION		
DESCRIPTION	MODEL	ORDER NO.
Draw wire for absolute encoder wire length 5000 mm, drum circumference 204.8 mm	DWA-5000	95B081440
Draw wire for integral encoder wire length 5000 mm, drum circumference 200 mm	DWI-5000	95B081460

**DIMENSIONS**

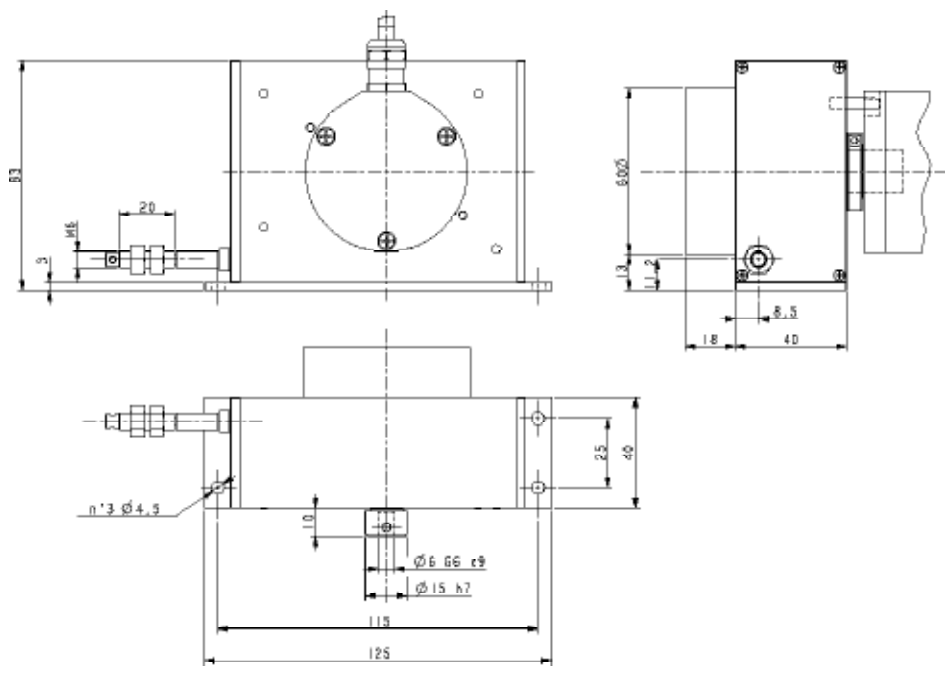

DW

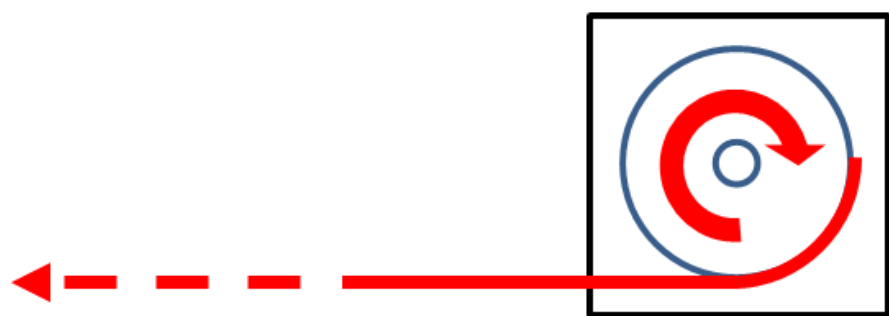

# LINEAR MEASUREMENT ACCESSORIES

## MW™

### Metric Wheel

Metric wheels are used with encoders mainly for length measuring applications and the accuracy is given by the ratio between the wheel circumference and encoder's resolution, e.g.:

500 mm / 8192 CPR = 0.061 mm per code

500 mm / 10000 PPR = 0.05 mm per pulse



#### APPLICATION

-Length measurement and positioning



#### MECHANICAL AND ENVIRONMENTAL SPECIFICATIONS

Wheel material	Plastic	
Wheel surface	Rubber (notched)	
Circumference	200 mm	500 mm
Diameter	63 mm	159 mm
Thickness	12 mm	24 mm
Hole diameter	Ø6 mm	Ø10 mm
Operating temperature	-25 to +85°C (-13 to 185°F)	
Storage temperature	-25 to +85°C (-13 to 185°F), 98% R.H. non condensing	



## MODEL SELECTION

DESCRIPTION	MODEL	ORDER NO.
Encoder metric wheel with circumference 200 mm	MW-200-D6	95B081480
Encoder metric wheel with circumference 500 mm	MW-500-D10	95B081490
Encoder metric wheel support with springs	MW-500-SPRING	95B081800

## DIMENSIONS

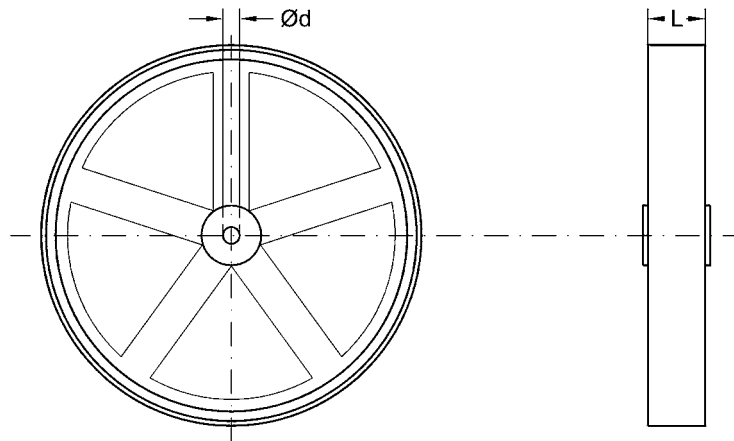

MW-200 ( $\varnothing d=6\text{mm}$ ,  $L=12\text{mm}$ )

MW-500 ( $\varnothing d=10\text{mm}$ ,  $L=24\text{mm}$ )

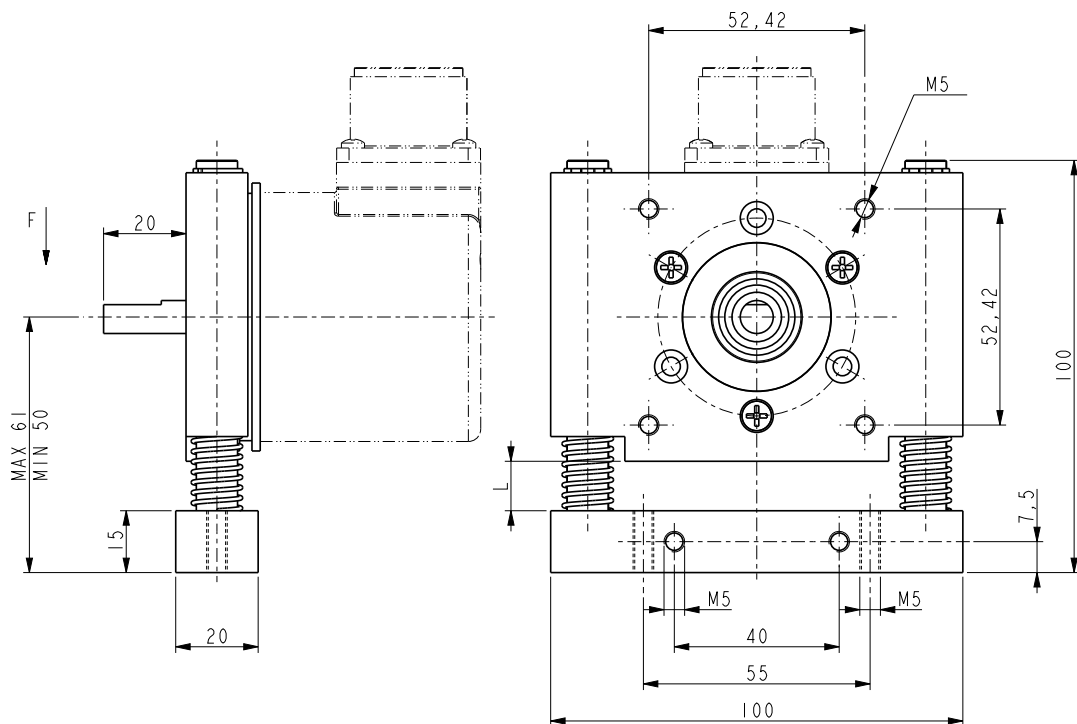

MW-500-SPRING



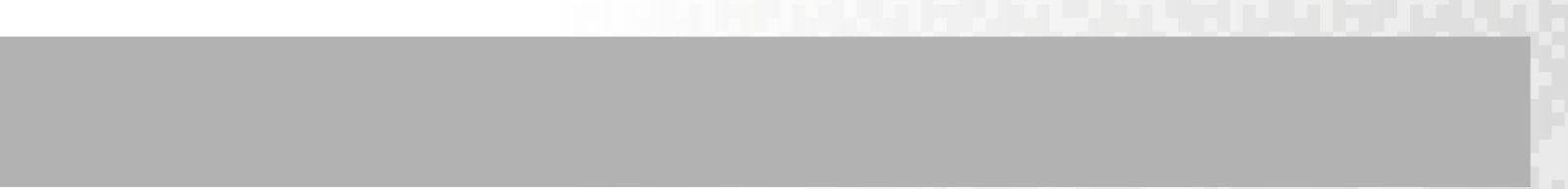

2025-2026 *Journal of the American Veterinary Medical Association* |  | [www.avma.org](http://www.avma.org)





[www.datalogic.com](http://www.datalogic.com)

Rev. 06, 11/2016



9C514300E